



#6797

Othello Console

H: 32" W: 44" D: 16"

Iron console table with slender vertical supports in an antique brass finish and topped with antiqued top.

QUICKSHIP

- DINING
- LIVING
- WORKSPACE
- BEDROOM
- OUTDOOR
- LIGHTING
- ACCESSORIES
- PROJECTS

SUITE NEWS

Home / Dining Table



Dining Table

Mark Albrecht, 2013

OVERVIEW

Mark Albrecht was trained as a sculptor and pursued his studies at the École Nationale Supérieure des Beaux-arts in Paris. He uses as few elements as possible to make pieces that are timeless, functional, and resilient. Albrecht's new Dining Table is a made-to-order table with a steel base and a hardwood top consistent with the designers minimalist aesthetic and mastery of materials.

- Base finishes include: black steel, satin stainless steel, polished steel, bronze or polished brass.
- Available with "The X," "The Square" or "The Cube" base
- Tabletop wood species available: black walnut, claro walnut, white oak (rift sawn, quarter sawn or flat sawn) or a variety of veneers.
- Square Base Dining Table: 100.0"w 45.0"d 29.0"h,

VIEW LARGER

rollover over image to zoom



ADD TO BINDER

REQUEST QUOTE

EMAIL PRINT SHARE

SUITE SUPPORT

Many of our products come in additional finishes and sizes. For questions, finish options and custom orders please contact showroomsales@suiteny.com or call 1-877-278-4836 Monday-Friday, 9am-6pm to speak to a design expert for advice and consultation.

SUITE NEW YORK RECOMMENDS

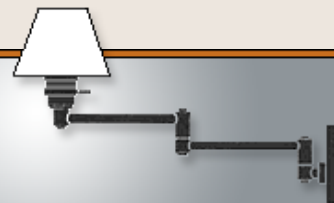

Thursday, August 28, 2014

[Table](#) | [Wall](#) | [Floor](#) | **[Pendant & Ceiling](#)** | [Specialty](#) | [Archive](#) [PDF downloads](#) | [Order a Nessen Binder](#) | [GSA](#)

[Home](#)

PRODUCTS

[About](#)

[Contact](#)

[Rep List](#)

[Price List](#)

[Find a Fixture](#)

[Designers](#)

[Photos](#)



ELLEN PENDANT LAMP

download PDF

NH826

Solid brass, 5" diam. canopy with hang straight. For ceiling box mounting. Two sockets controlled by separate wall switch. 100W max. each or appropriate cfl lamping. ULcUL listed.

SPECIFICATIONS:

Finishes:

Standard Metal Finishes:
Polished Brass, Brushed Brass,
Antique Brass, Polished Chrome,
Satin Chrome, Polished Nickel,
Satin Nickel

Optional Finishes:

Baked Enamel Paint

Shades:

Outer Shade: Titanium
Inner Shade: Ivory Silk Pongee
See other standard shades below. Custom fabrics may be special ordered - please contact your Nessen representative.

Shade Dimensions:

Outer Shade: B 24", T 24", H 6"
Inner Shade: B 20", T 20", H 10"

Related Items:

Designed by:

Wooding Design, Ltd.

For modifications and special contract orders, see [price list](#) or [contact](#) your Nessen representative



[click to enlarge](#)

Dimensions:

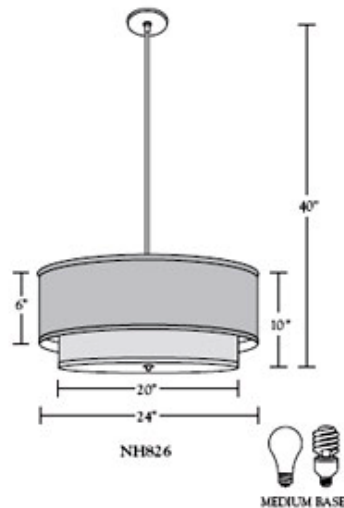

Photometrics:

no photometric data currently available

Need some help?
Call us: (914) 698-7799
www.nessenlighting.com

QUICKSHIP

DINING LIVING WORKSPACE BEDROOM OUTDOOR LIGHTING ACCESSORIES PROJECTS

SUITE NEWS

Home / Hampton Sofa

Hampton Sofa

CRD Verzelloni, 2011

\$7,190.00

OVERVIEW

Hampton is an elegant and refined two-seater sofa, a real modern reformulation of classic sofa design. The arm is the same depth as the sofa and seat cushions are parallel to the entire length of the sofa; thus highlighting its symmetry, square shape and simple, harmonious lines. An elegant bridge foot cast in burnished aluminum gives the sofa a visual lightness.

DETAILS

SHIPPING INFO

EMAIL PRINT SHARE

SUITE SUPPORT

Many of our products come in additional finishes and sizes. For questions, finish options and custom orders please contact showroomsales@suiteny.com or call 1-877-278-4836 Monday-Friday, 9am-6pm to speak to a design expert for advice and consultation.



VIEW LARGER

rollover over image to zoom



PRODUCT OPTIONS



23001 - Hampton Sofa - Sand
\$ 7,190.00

QUANTITY 1

ADD TO CART

ADD TO BINDER

COLOR: Sand

WHITE GLOVE

VIEW LARGER

HAMPTON VERSIONE A

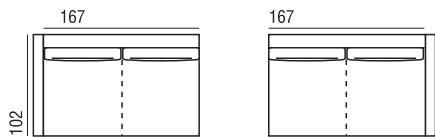

177
LATERALE 177 SX A
cuscino unico/cuscini divisi

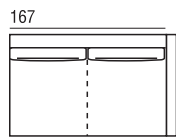

177
LATERALE 177 DX A
cuscino unico/cuscini divisi

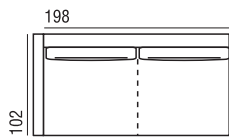

208
LATERALE 208 SX A
cuscino unico/cuscini divisi

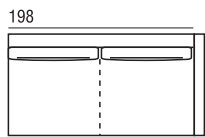

208
LATERALE 208 DX A
cuscino unico/cuscini divisi

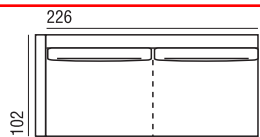

236
LATERALE 236 SX A
cuscino unico/cuscini divisi



236
LATERALE 236 DX A
cuscino unico/cuscini divisi

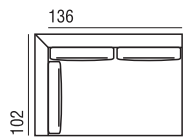

158
ANGOLO 158 SX A

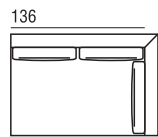

158
ANGOLO 158 DX A

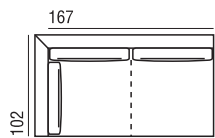

189
ANGOLO 189 SX A
cuscino unico/cuscini divisi

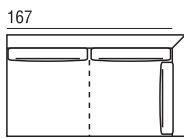

189
ANGOLO 189 DX A
cuscino unico/cuscini divisi

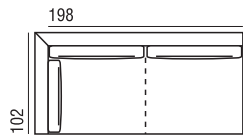

220
ANGOLO 220 SX A
cuscino unico/cuscini divisi

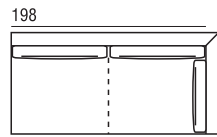

220
ANGOLO 220 DX A
cuscino unico/cuscini divisi

HAMPTON VERSIONE B

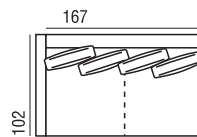

177
LATERALE 177 SX B
cuscino unico/cuscini divisi

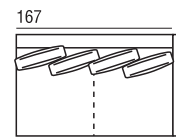

177
LATERALE 177 DX B
cuscino unico/cuscini divisi

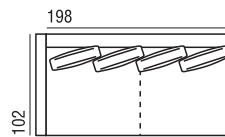

208
LATERALE 208 SX B
cuscino unico/cuscini divisi

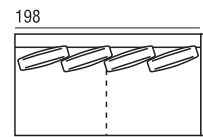

208
LATERALE 208 DX B
cuscino unico/cuscini divisi

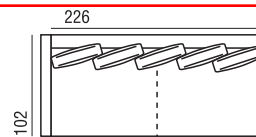

236
LATERALE 236 SX B
cuscino unico/cuscini divisi

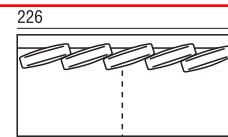

236
LATERALE 236 DX B
cuscino unico/cuscini divisi

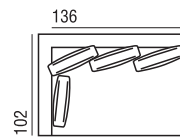

158
ANGOLO 158 SX B

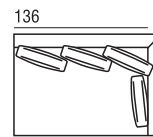

158
ANGOLO 158 DX B

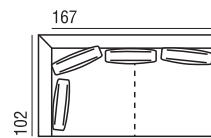

189
ANGOLO 189 SX B
cuscino unico/cuscini divisi

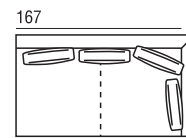

189
ANGOLO 189 DX B
cuscino unico/cuscini divisi

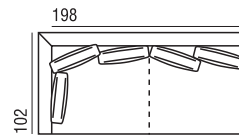

220
ANGOLO 220 SX B
cuscino unico/cuscini divisi

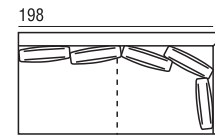

220
ANGOLO 220 DX B
cuscino unico/cuscini divisi

HAMPTON VERSIONE A

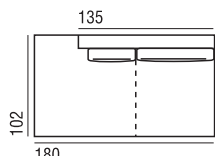

TERMINALE 180 SX A
cuscino unico/cuscini divisi

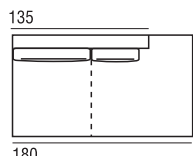

TERMINALE 180 DX A
cuscino unico/cuscini divisi

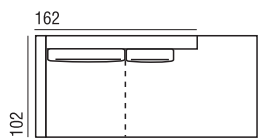

DORMEUSE 228 SX A
cuscino unico/cuscini divisi

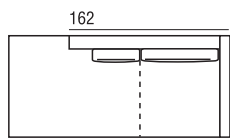

DORMEUSE 228 DX A
cuscino unico/cuscini divisi

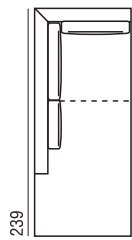

DORMEUSE ANGOLO 239 SX A
cuscino unico/cuscini divisi

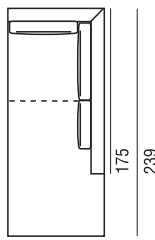

DORMEUSE ANGOLO 239 DX A
cuscino unico/cuscini divisi

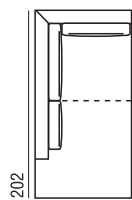

DORMEUSE ANGOLO 202 SX A
cuscino unico/cuscini divisi

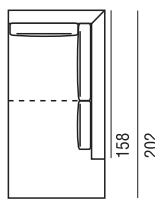

DORMEUSE ANGOLO 202 DX A
cuscino unico/cuscini divisi

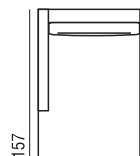

CHAISE LONGUE 110 SX A

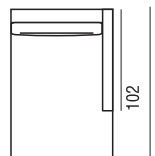

CHAISE LONGUE 110 DX A

HAMPTON VERSIONE B

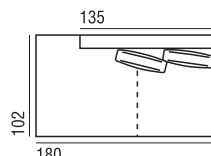

TERMINALE 180 SX B
cuscino unico/cuscini divisi

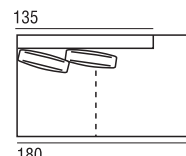

TERMINALE 180 DX B
cuscino unico/cuscini divisi

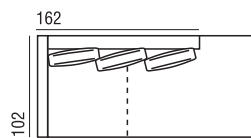

DORMEUSE 228 SX B
cuscino unico/cuscini divisi

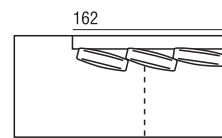

DORMEUSE 228 DX B
cuscino unico/cuscini divisi

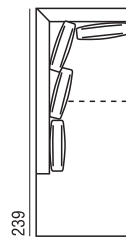

DORMEUSE ANGOLO 239 SX B
cuscino unico/cuscini divisi

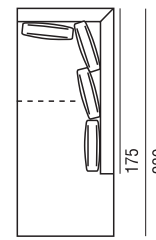

DORMEUSE ANGOLO 239 DX B
cuscino unico/cuscini divisi

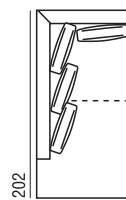

DORMEUSE ANGOLO 202 SX B
cuscino unico/cuscini divisi

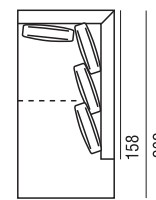

DORMEUSE ANGOLO 202 DX B
cuscino unico/cuscini divisi

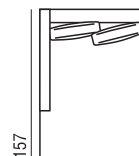

CHAISE LONGUE 110 SX B

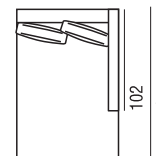

CHAISE LONGUE 110 DX B



Hampton Composizione descritta a pagina 306 Combination described at page 306 Zusammenstellung beschrieben auf Seite 306

HAMPTON VERSIONE A

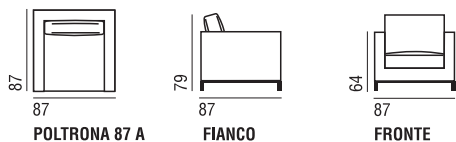

HAMPTON VERSIONE B

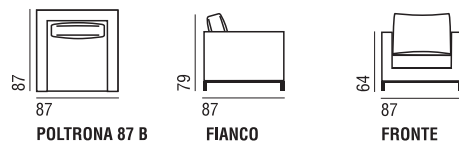

COMPLEMENTI

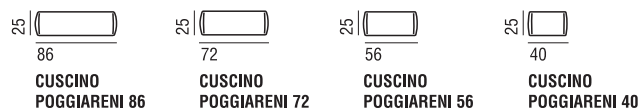
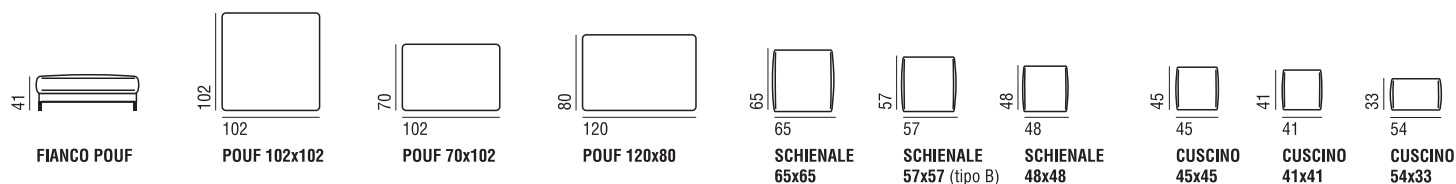

TAVOLINO ARGO

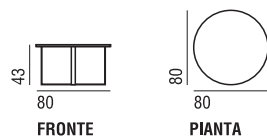

TAVOLINO JIM



BLOG TAVOLINO ROTONDO

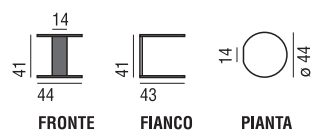

BLOG TAVOLINO RETTANGOLARE

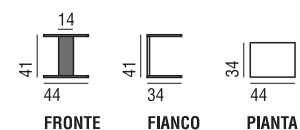

YABUPUSHELBERG

Project Name: **PARK HYATT / CARNEGIE- NYC**
 Project #: **07036**
 Issue Date: **08/31/2009**
 Revision(s): **03/27/2012** Δ 1
New Product

Item Number: **HOT-420-CG**
 Item Description: **Side Table- Custom to Bid**
 Area Name: **Hotel Room**

Item Quantity:

Manufacturer: By Custom Furniture Manufacturer	Source: By Custom Furniture Manufacturer
Address:	Address:
Phone:	Phone:
Fax:	Fax:
Contact:	Contact:
E-mail:	E-mail:
Web:	Web:

Description: Side Table- Custom to Bid

Width: 37cm
 Depth: 37cm
 Height: 60cm
 Top Mat'l/Finish: Brown Glossy Lacquer
 Base Mat'l/Finish: Glossy Black Nickel



Notes: Lcoation= Suites

Required Item(s) for Designer Approval Prior to Fabrication: Prepared By: CG

<input type="checkbox"/> Seaming Diagram	<input type="checkbox"/> Strike-Off	<input checked="" type="checkbox"/> Finish Sample	<input type="checkbox"/> Cutting	<input checked="" type="checkbox"/> Shop Dwgs	<input type="checkbox"/> Prototype	<input type="checkbox"/> Flame Certificate
--	-------------------------------------	---	----------------------------------	---	------------------------------------	--

Instructions:

- 1 Any materials used must be suitable for use in location specified and varying climatic situations.
- 2 All work is to be corner blocked, well fitted, double doweled, glued, and screwed into place. Joint glue must be of the best quality and any excess glue will be thoroughly cleaned.
- 3 All items are to be mill fabricated according to the size and design indicated on the approved shop drawings.
- 4 Legs and bases must be made of wood solids.
- 5 All drawer fronts will be as specified and should be made of lumber or veneer plywood.
- 6 Drawer sides, backs and sub fronts will be made of 13 mm (1/2") solid lumber or veneered plywood.

QUICKSHIP

DINING LIVING WORKSPACE BEDROOM OUTDOOR LIGHTING ACCESSORIES PROJECTS

SUITE NEWS

LIVING

Living / Floor / Read Noon

PREVIOUS 13 of 17 NEXT



VIEW LARGER

rollover over image to zoom



Read Noon

El Schmid, 2008

\$2,175.00

OVERVIEW

The desire for simplicity and the pleasure found in pure design led to a geometrical abstraction of natural branch forms in in turn, the Read Noon and entire Noon Collection.

Designer El Schmid is originally from Austria, where he was born in 1953. He started working with metal during his apprenticeship as a craftsman. In a second apprenticeship in Munich he became familiar with materials such as brass, bronze and silver and later studied graphic design, in which he obtained a degree with honors in "Corporate Identity Design". Together with his partner in Munich he founded Schmid & Stemann in 1981. In his own master workshop he dedicated 10 years to the creation of individual designer pieces, which influenced the Munich design-scene

DETAILS

- Base and stem in black lacquered iron, shade in warm gray textile.
- Base: 22.0"w 17.7"d 63.0"h Shade: 17.7"dia 11.8"h
- Shade textile: Arenal: 75% viscose, 25% polyamide, interior lined with vegetal paper.
- For avoiding electromagnetic pollution READ NOON is earthed.
- Bulb Information (not included): max. Halogen Classic A, ECO 105 W, E 27 alternativ Concentra Spot, R 80 100 W, E 27
- Manufactured in Germany by Zeitraum.
- Warranty: 2 years against manufacturing defects.
- Also available with a white lamitex shade or a textile shade in white or black.
- Care Instructions: Your product arrives with detailed care instructions. If you need more information please

SHIPPING INFO

QUANTITY 1

ADD TO BINDER

ADD TO CART



Mellow

Formstelle, 2010

OVERVIEW

the back of the headboard add a touch of sophistication and provide essential support for the soft back cushions.

- Solid wood bed available in ash, oak, cherry, American walnut or European walnut. Back element includes laced leather straps and two pillows filled with duck down and foam core.
- Fully removable covers available in elmo-leather, COM or COL.
- Solid wood bed in Twin, Full, Queen, King and California King sizes
- Twin: 40.0"w 86.0"d Full: 55.0"w 86.0"d Queen: 63.0"w 91.0"d King: 78.9"w 91.0"d California King: 74.1"w 95.0"d
- Bedside height: 12.6"h
- Headboard height (without pillows): 25.2"h
- Recommended with a mattress thickness of 4.7"- 5.5"

VIEW LARGER

rollover over image to zoom



ADD TO BINDER

REQUEST QUOTE

EMAIL PRINT + SHARE

SUITE SUPPORT

Many of our products come in additional finishes and sizes. For questions, finish options and custom orders please contact showroomsales@suiteny.com or call 1-877-278-4836 Monday-Friday, 9am-6pm to speak to a design expert for advice and consultation.

SUITE NEW YORK RECOMMENDS



Project Name: **PARK HYATT / CARNEGIE- NYC**
 Project #: **07036**
 Issue Date: **08/31/2009**
 Revision(s): **10/26/2012** Δ4
 New Finishes

Item Number: **HOT-404-CG**
 Item Description: **Bedside Table- Custom**
 Area Name: **Hotel Room**

Item Quantity:

Manufacturer: By Millwork Contractor
 Address:

Source: By Millwork Contractor
 Address:

Phone:
 Fax:
 Contact:
 E-mail:
 Web:

Phone:
 Fax:
 Contact:
 E-mail:
 Web:

Description: Custom Bedside Table
 Refer to drawing HOT-404-CG for details

Finish References: ML-01 Plated Finish / Brass Substrate -
 MR--13 NGM Bronze Mirror / 1" Bevel / 1/4" Thick -
 MR--17 Bronze Satin Mirror w/ Enduroshield protective
 coating - TOP
 WD-02 Claro Walnut / Quarter Cut / Oil / Varnish /
 Hand-rubbed w/ Wax -

Notes: Location= Guestrooms

Required Item(s) for Designer Approval Prior to Fabrication:

Prepared By: MR

<input type="checkbox"/> Seaming Diagram	<input type="checkbox"/> Strike-Off	<input checked="" type="checkbox"/> Finish Sample	<input type="checkbox"/> Cutting	<input checked="" type="checkbox"/> Shop Dwgs	<input type="checkbox"/> Prototype	<input type="checkbox"/> Flame Certificate
--	-------------------------------------	---	----------------------------------	---	------------------------------------	--

Instructions:

- Any materials used must be suitable for use in location specified and varying climatic situations.
- All work is to be corner blocked, well fitted, double doweled, glued, and screwed into place. Joint glue must be of the best quality and any excess glue will be thoroughly cleaned.
- All items are to be mill fabricated according to the size and design indicated on the approved shop drawings.
- Legs and bases must be made of wood solids.
- All drawer fronts will be as specified and should be made of lumber or veneer plywood.

Project Name: **PARK HYATT / CARNEGIE- NYC**
 Project #: **07036**
 Issue Date: **08/31/2009**
 Revision(s): **10/26/2012** ▲4

Item Number: **HOT-404-CG**
 Item Description: **Bedside Table- Custom**
 Area Name: **Hotel Room**

Item Quantity:

Manufacturer: By Millwork Contractor

Source: By Millwork Contractor

Instructions:

- 6 Drawer sides, backs and sub fronts will be made of 13 mm (1/2") solid lumber or veneered plywood.
- 7 Drawer bottoms will be made of solid lumber or veneered plywood. Drawer bottoms may not be made of Masonite or particleboard.
- 8 Drawer sides will be dovetailed or butterfly jointed and glued under pressure. The dovetails will be milled true and even.
- 9 Drawer and door interiors must be veneered and finished to match the exterior of the unit.
- 10 Drawer and door interiors will be sanded smooth, lacquered and waxed.
- 11 All drawers will have a stop mechanism that is removable when required for repairs or access.
- 12 All cabinet doors will be as specified and should be made of 19 mm (3/4") lumber or veneered plywood or as required.
- 13 Cabinet door interiors must be veneered and finished to match the exterior of the unit.
- 14 All adjustable shelving will be made of solid wood or veneered plywood unless otherwise specified.
- 15 For all shelves, the top, bottom, and side edges must match the exterior of the unit.
- 16 All casegood hardware and accessories will be furnished and installed by the vendor and must be indicated on the shop drawings.
- 17 All drawers and pull out shelves will have concealed, undermounted hardware. Full extension, metal drawer glides or shelf slides with ball bearing nylon rollers are required. These should be self-closing and have stops.
- 18 All casegood and softgood legs and bases will have self-leveling adjustable nylon contract quality carpet glides, appropriate to the weight of the piece and the floor finish on which the casegood will be placed.
- 19 All glides and levelers will be non-rusting.
- 20 The casegood vendor will supply templates for all glass tops when supplied by others.

YABUPUSHELBERG

55 BOOTH AVENUE TORONTO ONTARIO CANADA
 M4M 2M3 TELEPHONE 416.778.9779 FAX 416.778.9747
 4F-138 SPRING STREET YORK N.Y. 10012-3854
 T E L E P H O N E 212.226.0808 F A X 212.226.0666
 EMAIL DESIGN@YABUPUSHELBERG.COM

GENERAL NOTES

1. ALL MDF TO BE FINISHED WD2
2. DENOTES WOOD GRAIN DIRECTION.
3. ALL METAL TO BE FINISHED ML1
4. ALL MIRROR TO BE FINISHED MR13 UNLESS NOTED OTHERWISE

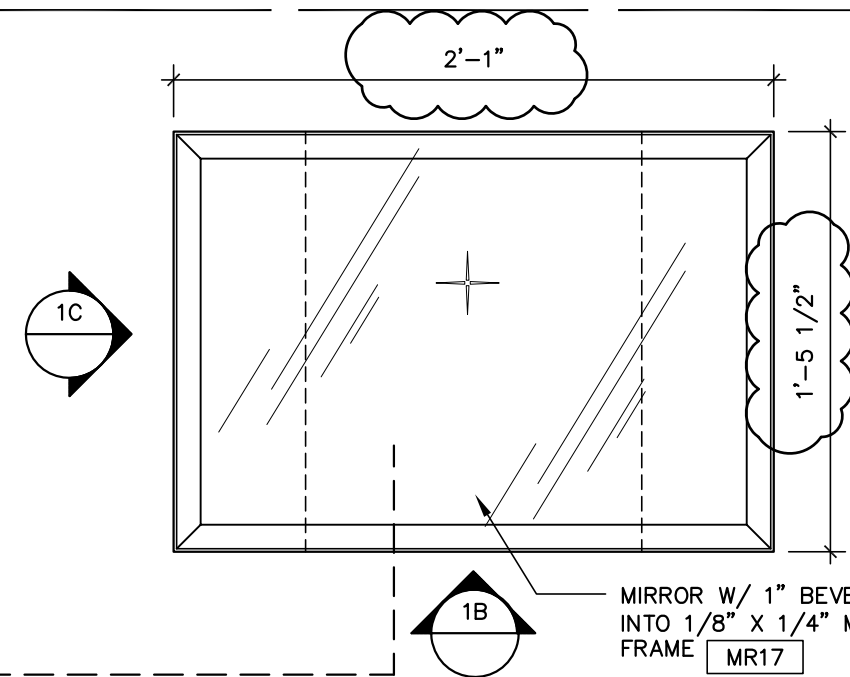

1A PLAN
 SCALE: 1 1/2" = 1'-0"

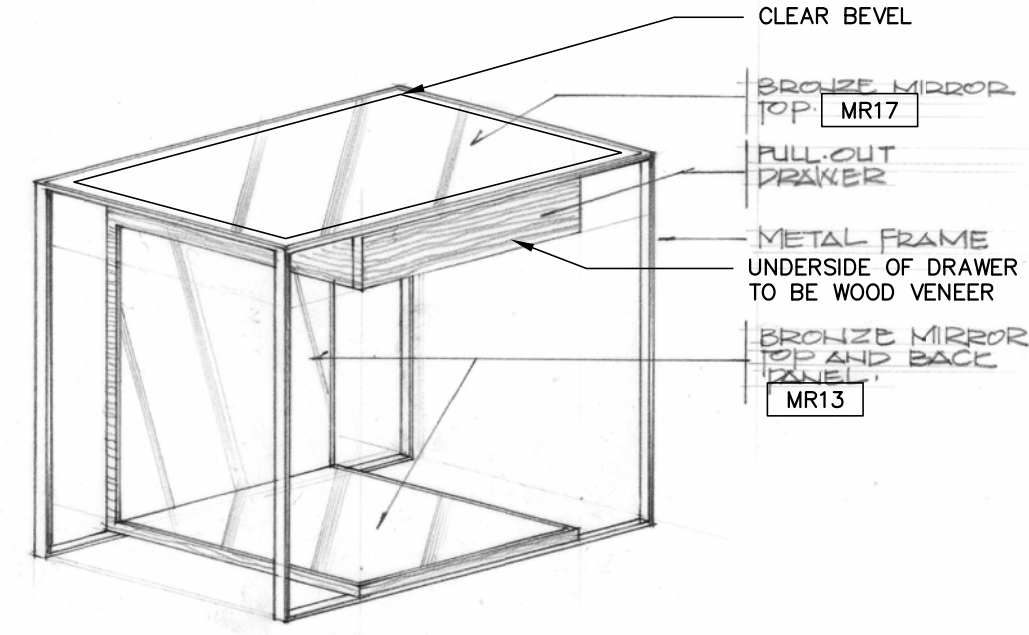

1D AXONOMETRIC
 SCALE: 1 1/2" = 1'-0"

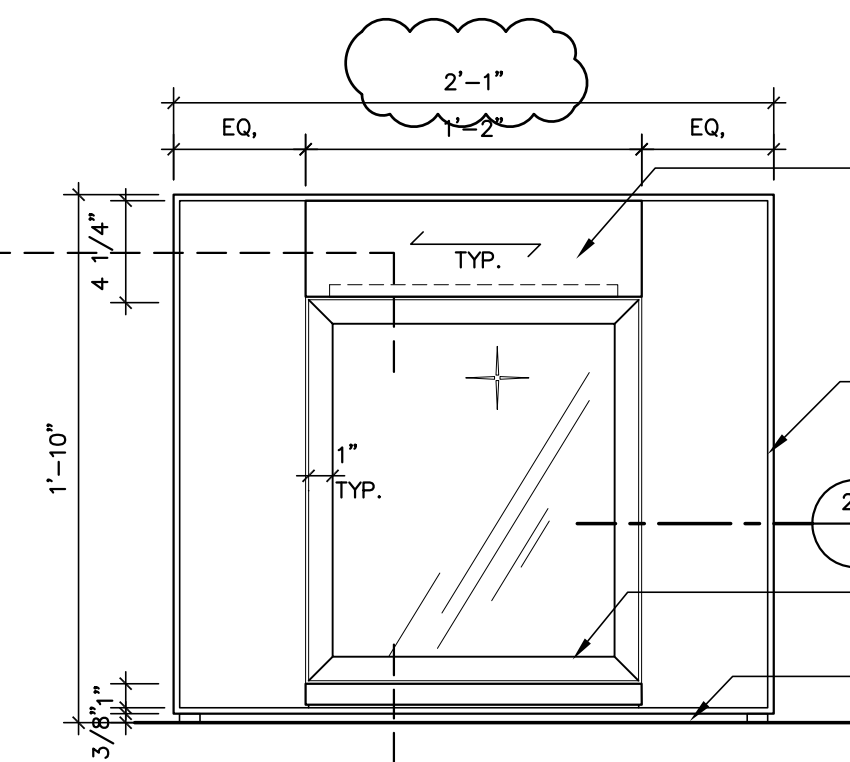

1B FRONT ELEVATION
 SCALE: 1 1/2" = 1'-0"

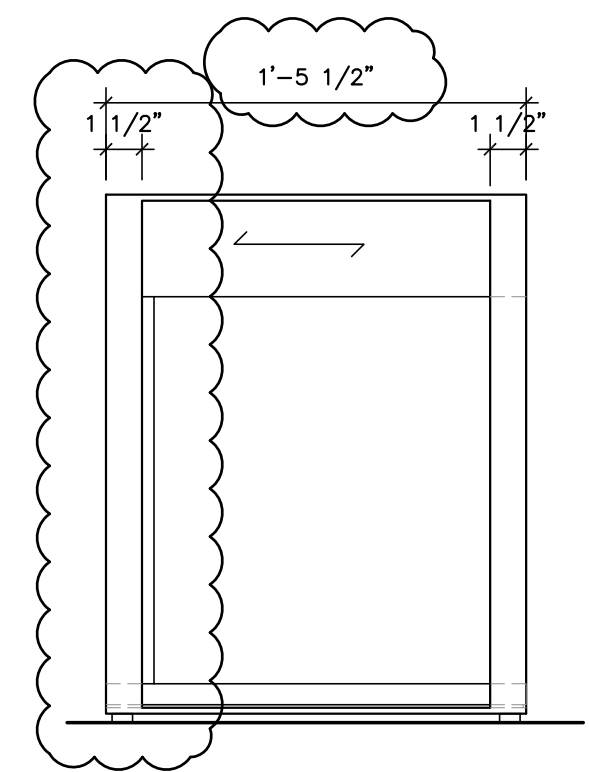

1C SIDE ELEVATION
 SCALE: 1 1/2" = 1'-0"

ISSUE	ISSUE DATE
1 100% CD	NOV 4,2011
2 BULLETIN 8 REVISION #1	OCT 26,2012

REVISION REVISION DATE
 PROJECT PROJECT NO. **07036**
 PARK HYATT - CARNEG
 57TH STREET BLDG.
 WEST 57TH STREET
 NEW YORK, NEW YORK 10019

DRAWING DRAWING NO.
 HOT-404-CG
 1 OF 2
 FLOORS 4-18
 HOTEL ROOMS
 BEDSIDE TABLE

SCALE DATE
 AS NOTED 11.04.2011
 DRAWN BY CHECKED BY
 AG/SP

CONTRACTOR MUST CHECK AND VERIFY ALL JOB DIMENSIONS, DRAWINGS, DETAILS AND SPECIFICATIONS REPORT ANY DISCREPANCIES TO DESIGNERS BEFORE PROCEEDING WITH WORK

GENERAL NOTES

1. ALL MDF TO BE FINISHED WD2
2. DENOTES WOOD GRAIN DIRECTION.
3. ALL METAL TO BE FINISHED ML1
4. ALL MIRROR TO BE FINISHED MR13 UNLESS NOTED OTHERWISE

ISSUE ISSUE DATE

1	100% CD	NOV 4, 2011
2	BULLETIN 8 REVISION #1	OCT 26, 2012

REVISION REVISION DATE

PROJECT PROJECT NO. **07036**
PARK HYATT – CARNEGIE
57TH STREET BLDG.
WEST 57TH STREET
NEW YORK, NEW YORK 10019

DRAWING DRAWING NO.
HOT-404-CG
2 OF 2

FLOORS 4-18
HOTEL ROOMS
BEDSIDE TABLE

SCALE DATE
AS NOTED 11.04.2011
DRAWN BY CHECKED BY
AG/SP

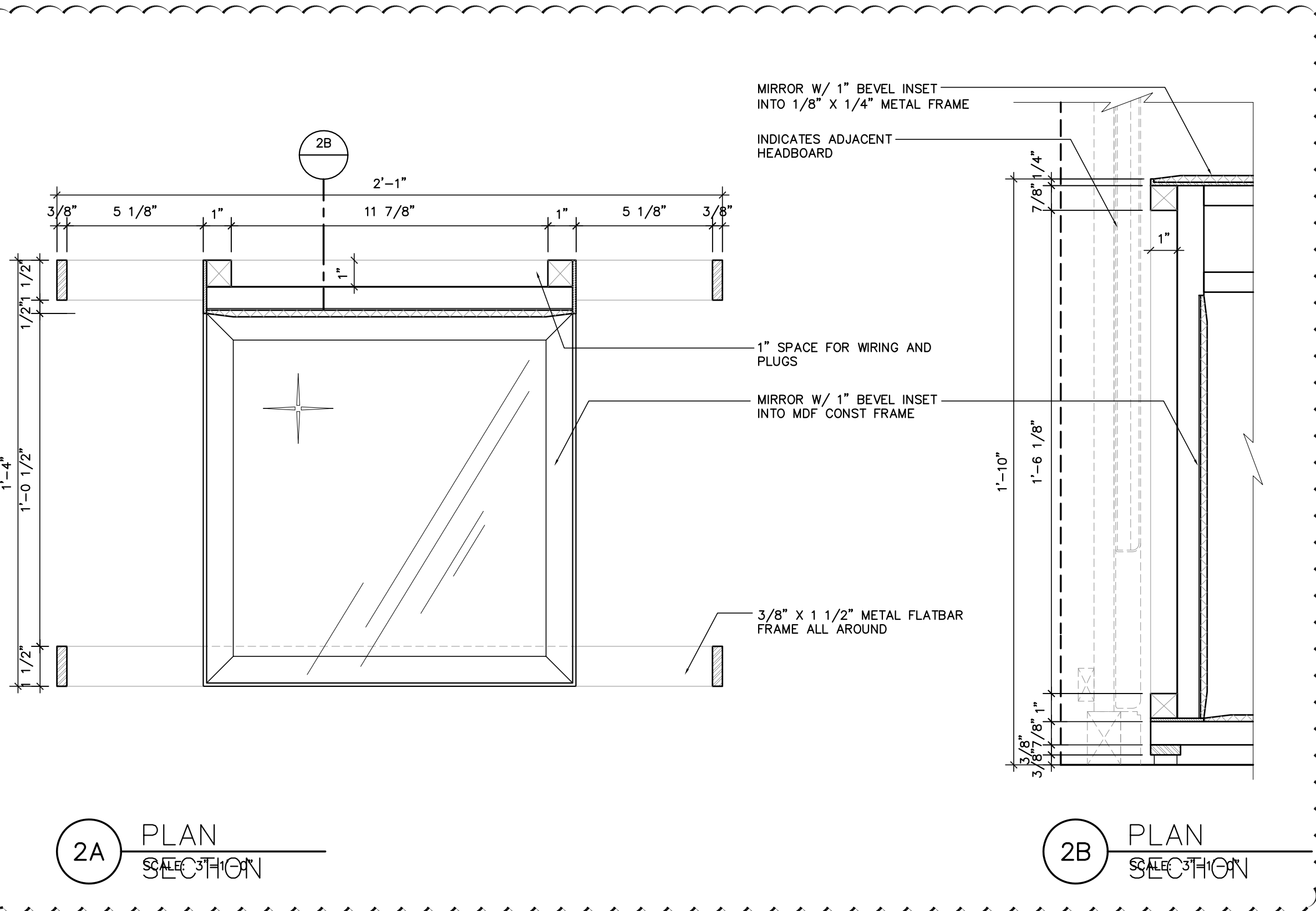

2A PLAN SECTION
SCALE: 3/4"=1'-0"

2B PLAN SECTION
SCALE: 3/4"=1'-0"



Project Name: **PARK HYATT / CARNEGIE- NYC**
 Project #: **07036**
 Issue Date: **08/31/2009**
 Revision(s): **09/30/2011** Δ 3
New Notes and Drawing

Item Number: **HOT-501B-LT**
 Item Description: **Bedside Lamp- Custom**
 Area Name: **Hotel Room**

Item Quantity:

Manufacturer: By Custom Lighting Manufacturer	Source: By Custom Lighting Manufacturer
Address:	Address:
Phone:	Phone:
Fax:	Fax:
Contact:	Contact:
E-mail:	E-mail:
Web:	Web:

Description: Custom Bedside Lamp
 Refer to drawing HOT-501-LT for details.

Cord Color: Black

Shade/Diffuser Material: White Linen Shade

Dimmer: Dimmer to be on base

Finish References: ML-01 Plated Finish / Brass Substrate - BASE

Notes: HOT-501A-LT and HOT-501B-LT are the same fixture. The shade and stem are to remain in the same orientation, but the base is to be mirrored for right and left handed conditions.
 HOT-501A-LT to have left handed orientation.
 HOT-501B-LT to have right handed orientation.

Required Item(s) for Designer Approval Prior to Fabrication: Prepared By: MR

<input type="checkbox"/> Seaming Diagram	<input type="checkbox"/> Strike-Off	<input checked="" type="checkbox"/> Finish Sample	<input type="checkbox"/> Cutting	<input checked="" type="checkbox"/> Shop Dwgs	<input checked="" type="checkbox"/> Prototype	<input type="checkbox"/> Flame Certificate
--	-------------------------------------	---	----------------------------------	---	---	--

1. MANUFACTURE TO SUBMIT CHAMPAGNE METAL FINISH FOR APPROVAL

2. SUBMIT FABRIC FOR APPROVAL

NOTE: HOT-501A-LEFT ORIENTATION
HOT-501B-RIGHT ORIENTATION

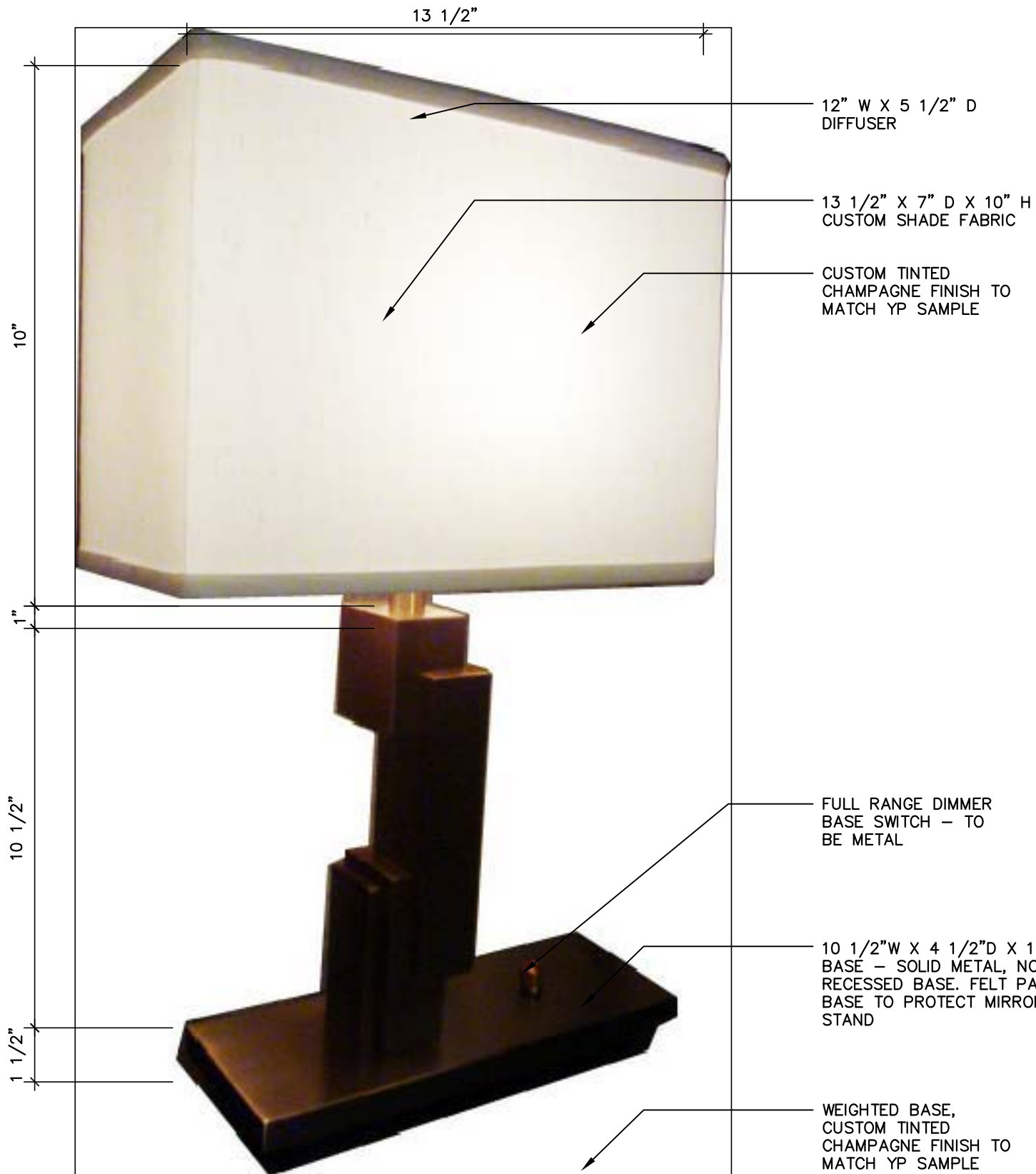

2 IMAGE
N.T.S.



3 IMAGE
N.T.S.

1 IMAGE
N.T.S.

ISSUE ISSUE DATE

REVISION REVISION DATE
PROJECT PROJECT NO. 07036
PARK HYATT - CARNEGIE
57TH STREET BLDG.
WEST 57TH STREET
NEW YORK, NEW YORK 10019

DRAWING DRAWING NO.
HOT-501-LT
1 OF 1

GUEST ROOMS
NIGHT STAND
TABLE LAMP

SCALE DATE
AS NOTED SEPT. 2011
DRAWN BY CHECKED BY
RA



Project Name: **PARK HYATT / CARNEGIE- NYC**
 Project #: **07036**
 Issue Date: **08/31/2009**
 Revision(s): **09/14/2012** Δ5
 New Fabric and New Dimensions

Item Number: **HOT-800-SG**
 Item Description: **Lounge Chair- Custom**
 Area Name: **Hotel Room**

Item Quantity:

Manufacturer: By Custom Furniture Manufacturer
 Address:
 Phone:
 Fax:
 Contact:
 E-mail:
 Web:

Source: By Custom Furniture Manufacturer
 Address:
 Phone:
 Fax:
 Contact:
 E-mail:
 Web:

Description: Custom Lounge Chair
 Refer to drawing HOT-800-LT for details

Width: 28"
 Depth: 30.75"
 Height: 28.75"
 Seat Height: 16-1/2"

Finish References: WD-38 Solid Walnut / 20% Sheen -
 FB-101 hide -

Notes: Location= Guestrooms

Required Item(s) for Designer Approval Prior to Fabrication:

Prepared By: MR

<input type="checkbox"/> Seaming Diagram	<input type="checkbox"/> Strike-Off	<input checked="" type="checkbox"/> Finish Sample	<input checked="" type="checkbox"/> Cutting	<input checked="" type="checkbox"/> Shop Dwgs	<input checked="" type="checkbox"/> Prototype	<input type="checkbox"/> Flame Certificate
--	-------------------------------------	---	---	---	---	--

Instructions:

- 1 Any materials used must be suitable for use in location specified and varying climatic situations.
- 2 Vendors are obligated to ensure custom designed seating is contract quality and appropriate for the use intended.
- 3 All items are to be mill fabricated according to the size and design indicated on the approved shop drawings.
- 4 Legs and bases must be made of wood solids.
- 5 All upholstered seams are to be double machine stitched with pre-shrunk threads.

Project Name: **PARK HYATT / CARNEGIE- NYC**

Item Number: **HOT-800-SG**

Project #: **07036**

Item Description: **Lounge Chair- Custom**

Issue Date: **08/31/2009**

Area Name: **Hotel Room**

Revision(s): **09/14/2012 Δ5**

Item Quantity:

Manufacturer: By Custom Furniture Manufacturer

Source: By Custom Furniture Manufacturer

Instructions:

- 6 All upholstered items will be framed using hardwood solids only.
- 7 All upholstered items will be finished as indicated on the approved shop drawings and specifications.
- 8 All Cuttings for Approval (CFA's) are to be sent directly to the Interior Designer by the vendor.
- 9 Cushions will have non-rusting concealed zipper closures.

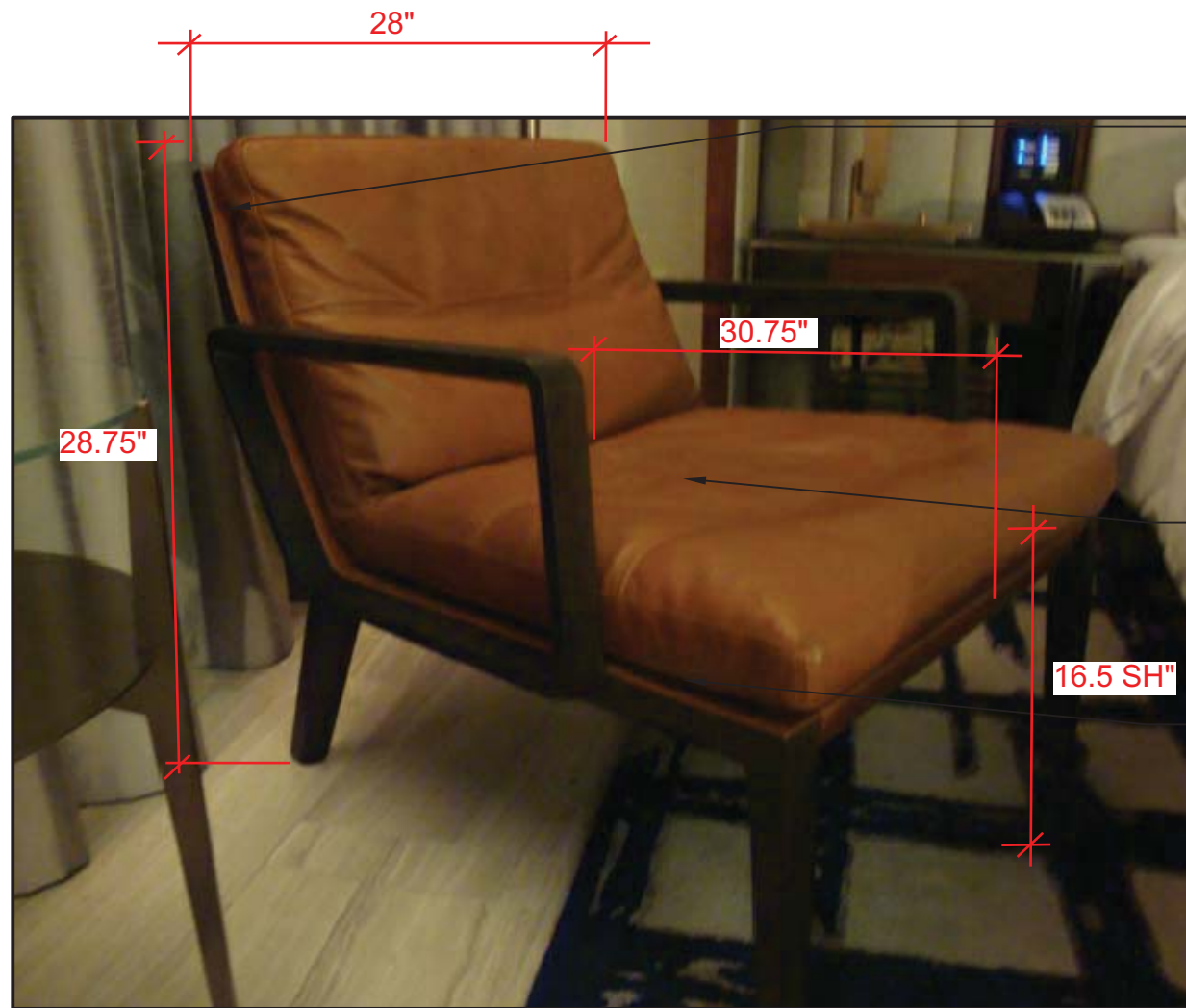

BACK DETAIL TO BE WOOD INSTEAD OF LEATHER

SEAT TO BE REMOVABLE

UNDERSIDE OF CUSHION TO BE FABRIC TO MATCH LEATHER, INSTEAD OF LEATHER

GENERAL NOTES

1. SEAT CUSHION TO BE HAND-ROLLED FRENCH MATTRESS, HAND WELTED AND HAND STUFFED WITH SHEEP'S WOOL 4" THICK
2. ALL FABRIC TO BE FB101
3. ALL WOOD FINISH TO BE WD2
4.  INDICATES THE DIRECTION OF WOOD GRAIN

ISSUE ISSUE DATE

REVISION REVISION DATE
 PROJECT PROJECT NO. 07036

PARK HYATT - CARNEGIE
57TH STREET BLDG.
 WEST 57TH STREET
 NEW YORK, NEW YORK 10019

DRAWING DRAWING NO.
 HOT-800-SG

LOUNGE CHAIR 1 OF 1
GUEST ROOMS

SCALE DATE
 AS NOTED 09.30.2011
 DRAWN BY CHECKED BY
 RA

1 IMAGE
 N.T.S.



Project Name: **PARK HYATT / CARNEGIE- NYC**
 Project #: **07036**
 Issue Date: **08/31/2009**
 Revision(s): **09/30/2011** Δ 2
New Notes and Drawing

Item Number: **HOT-402-CG**
 Item Description: **Side Table- Custom**
 Area Name: **Hotel Room**

Item Quantity:

Manufacturer: By Custom Furniture Manufacturer	Source: By Custom Furniture Manufacturer
Address:	Address:
Phone:	Phone:
Fax:	Fax:
Contact:	Contact:
E-mail:	E-mail:
Web:	Web:

Description: Custom Side Table
 Refer to drawing HOT-402-CG for details.

Top Mat'l/Finish: 1/4" thick low iron tempered starfire clear glass

Finish References: ML-01 Plated Finish / Brass Substrate -

Notes: Glides are required.
 Clips are required to secure glass top to metal base.
 Location= Guestrooms

Required Item(s) for Designer Approval Prior to Fabrication: Prepared By: MR

<input type="checkbox"/> Seaming Diagram	<input type="checkbox"/> Strike-Off	<input checked="" type="checkbox"/> Finish Sample	<input type="checkbox"/> Cutting	<input checked="" type="checkbox"/> Shop Dwgs	<input type="checkbox"/> Prototype	<input type="checkbox"/> Flame Certificate
--	-------------------------------------	---	----------------------------------	---	------------------------------------	--

Instructions:

- 1 Any materials used must be suitable for use in location specified and varying climatic situations.
- 2 All work is to be corner blocked, well fitted, double doweled, glued, and screwed into place. Joint glue must be of the best quality and any excess glue will be thoroughly cleaned.
- 3 All items are to be mill fabricated according to the size and design indicated on the approved shop drawings.
- 4 Legs and bases must be made of wood solids.
- 5 All drawer fronts will be as specified and should be made of lumber or veneer plywood.
- 6 Drawer sides, backs and sub fronts will be made of 13 mm (1/2") solid lumber or veneered plywood.

Project Name: **PARK HYATT / CARNEGIE- NYC**
 Project #: **07036**
 Issue Date: **08/31/2009**
 Revision(s): **09/30/2011** Δ 2

Item Number: **HOT-402-CG**
 Item Description: **Side Table- Custom**
 Area Name: **Hotel Room**

Item Quantity:

Manufacturer: By Custom Furniture Manufacturer
 Address:

Source: By Custom Furniture Manufacturer
 Address:

Phone:

Phone:

Fax:

Fax:

Contact:

Contact:

E-mail:

E-mail:

Web:

Web:

Instructions:

- 7 Drawer bottoms will be made of solid lumber or veneered plywood. Drawer bottoms may not be made of Masonite or particleboard.
- 8 Drawer sides will be dovetailed or butterfly jointed and glued under pressure. The dovetails will be milled true and even.
- 9 Drawer and door interiors must be veneered and finished to match the exterior of the unit.
- 10 Drawer and door interiors will be sanded smooth, lacquered and waxed.
- 11 All drawers will have a stop mechanism that is removable when required for repairs or access.
- 12 All cabinet doors will be as specified and should be made of 19 mm (3/4") lumber or veneered plywood or as required.
- 13 Cabinet door interiors must be veneered and finished to match the exterior of the unit.
- 14 All adjustable shelving will be made of solid wood or veneered plywood unless otherwise specified.
- 15 For all shelves, the top, bottom, and side edges must match the exterior of the unit.
- 16 All casegood hardware and accessories will be furnished and installed by the vendor and must be indicated on the shop drawings.
- 17 All drawers and pull out shelves will have concealed, undermounted hardware. Full extension, metal drawer glides or shelf slides with ball bearing nylon rollers are required. These should be self-closing and have stops.
- 18 All casegood and softgood legs and bases will have self-leveling adjustable nylon contract quality carpet glides, appropriate to the weight of the pieced and the floor finish on which the casegood will be placed.
- 19 All glides and levelers will be non-rusting.
- 20 The casegood vendor will supply templates for all glass tops when supplied by others.

GENERAL NOTES

- 1. ALL METAL TO BE FINISHED ML1

ISSUE ISSUE DATE

1 BULLETIN #7	OCT 3 2011
---------------	------------

REVISION REVISION DATE

PROJECT PROJECT NO. 07036

PARK HYATT - CARNEGIE
57TH STREET BLDG.
 WEST 57TH STREET
 NEW YORK, NEW YORK 10019

DRAWING DRAWING NO.

HOT-402-CG
 1 OF 1

FLOORS 4-18
HOTEL ROOMS
SIDE TABLE

SCALE DATE

AS NOTED 08.05.2011

DRAWN BY CHECKED BY

AG/SP



1C SIDE ELEVATION
 SCALE: 1 1/2" = 1'-0"

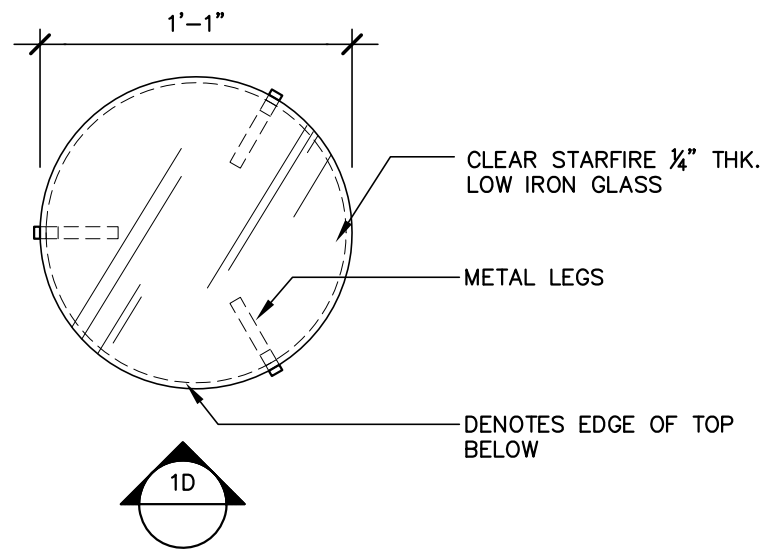
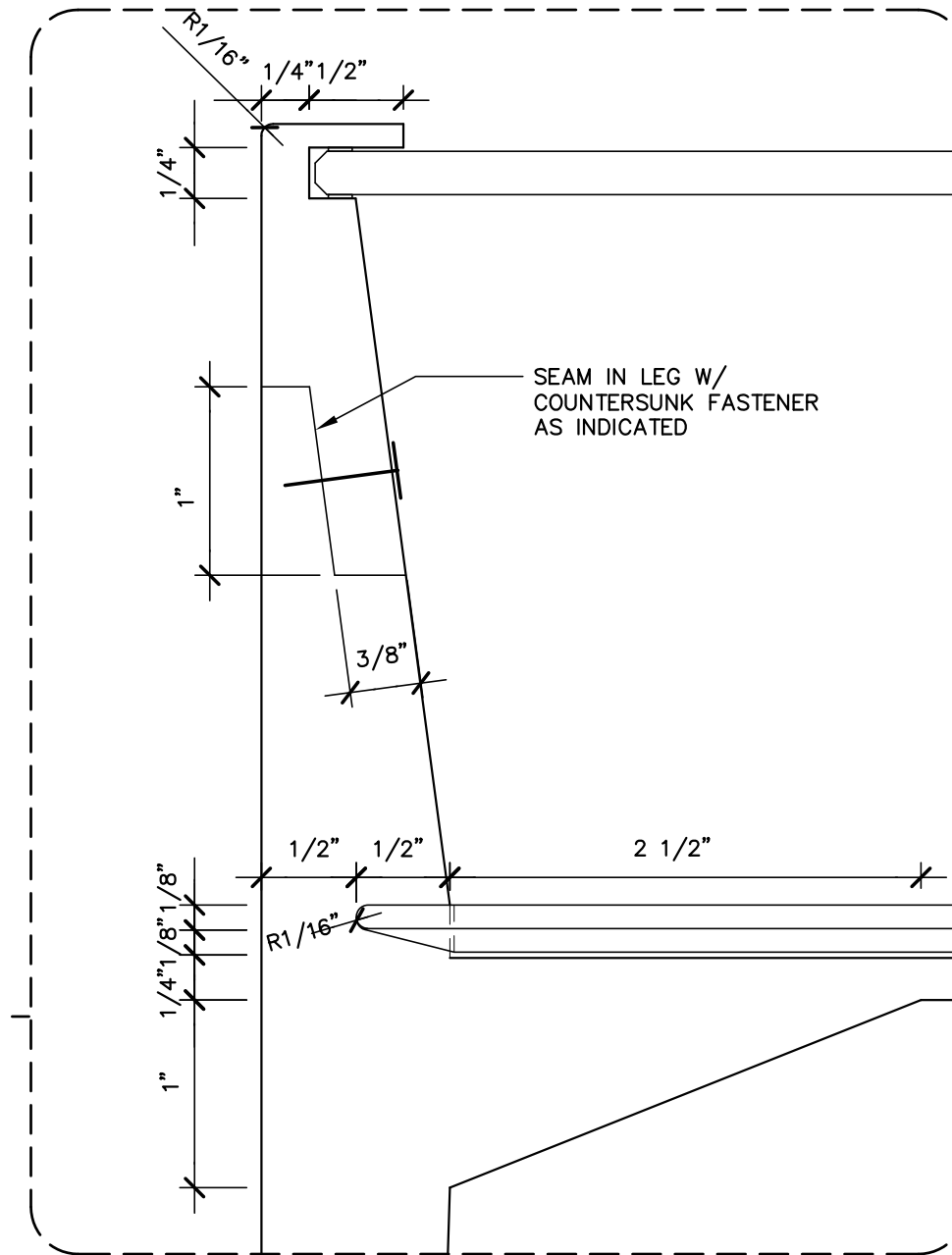

1A PLAN DETAIL
 SCALE: 1 1/2" = 1'-0"

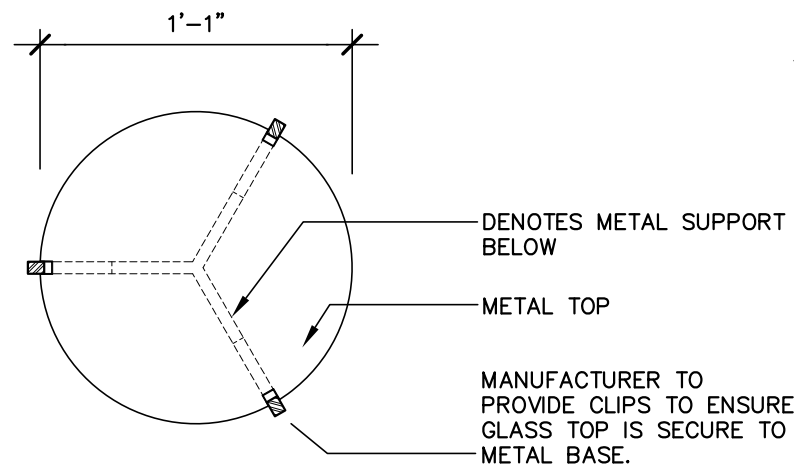

1B PLAN DETAIL
 SCALE: 1 1/2" = 1'-0"

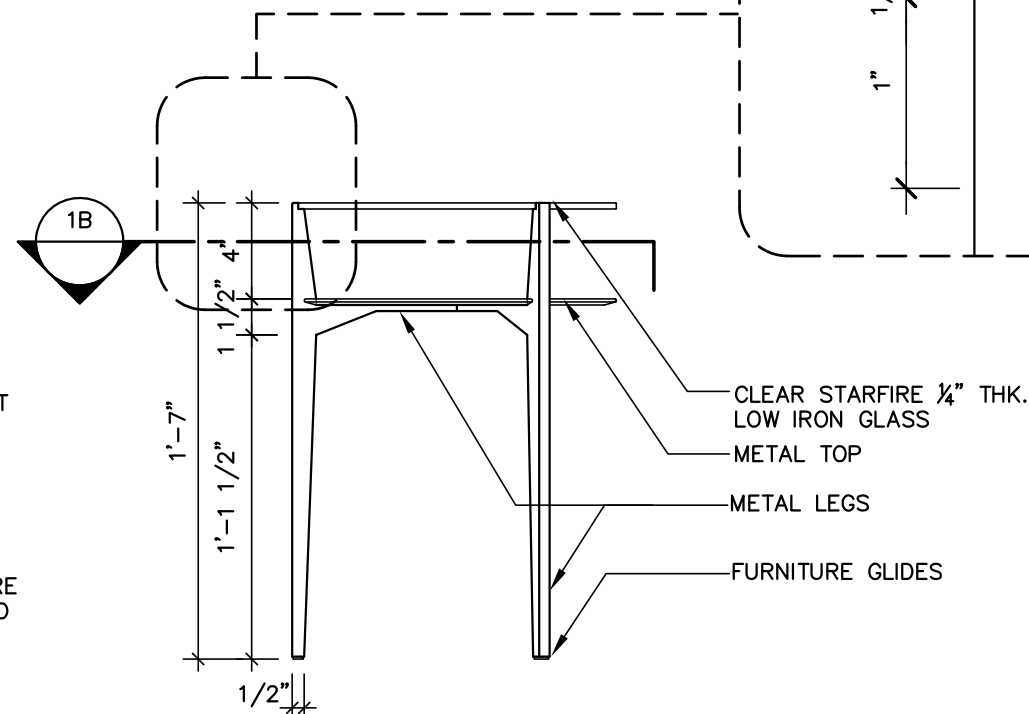

1D ELEVATION
 SCALE: 1 1/2" = 1'-0"

YABUPUSHELBERG

Project Name: **PARK HYATT / CARNEGIE- NYC**
 Project #: **07036**
 Issue Date: **08/31/2009**
 Revision(s): **09/30/2011** Δ 2
New Item

Item Number: **HOT-500-LT**
 Item Description: **Floor Lamp- Custom**
 Area Name: **Hotel Room**

Item Quantity:

Manufacturer: By Custom Lighting Manufacturer	Source: By Custom Lighting Manufacturer
Address:	Address:
Phone:	Phone:
Fax:	Fax:
Contact:	Contact:
E-mail:	E-mail:
Web:	Web:

Description: Custom Floor Lamp
 Refer to drawing HOT-500-LT for details

Cord Color: Black
 Lamp Type: Incandescent
 Lamp Wattage: 100W max
 UL Listing: UL Listing Required
 Shade/Diffuser Material: Grey Linen Shade
 Shade/Diffuser Dimensions: 1'-7" W x 8" H
 Finish References: ML-01 Plated Finish / Brass Substrate -



Required Item(s) for Designer Approval Prior to Fabrication:

Prepared By: HY

<input type="checkbox"/> Seaming Diagram	<input type="checkbox"/> Strike-Off	<input checked="" type="checkbox"/> Finish Sample	<input type="checkbox"/> Cutting	<input checked="" type="checkbox"/> Shop Dwgs	<input checked="" type="checkbox"/> Prototype	<input type="checkbox"/> Flame Certificate
--	-------------------------------------	---	----------------------------------	---	---	--

Instructions:

- 1 Cords are to be a minimum of 2440 mm (8'-0" long), unless noted otherwise. Cords shall be insulated and grounded.
- 2 Lamps will have a weighted base to ensure stability & will have felt bottoms or other non-marking material.
- 3 Pendants and or flush mounted fixtures must be hard wired to an electrical J-box and activated by a wall switch or the dimming system.
- 4 Purchasing Agent is responsible for ensuring fixture complies with local power supply and local codes.
- 5 Purchasing Agent is responsible for supplying all lamps for specified fixtures.

YABUPUSHELBERG

55 BOOTH AVENUE TORONTO ONTARIO CANADA
 M4M 2M3 TELEPHONE 416.778.9779 FAX 416.778.9747
 4F-138 SPRING STREET NEW YORK NEW YORK USA 10012-3854
 TELEPHONE 212.226.0808 FAX 212.226.0666
 EMAIL DESIGN@YABUPUSHELBERG.COM

GENERAL NOTES

1. MANUFACTURE TO SUBMIT CHAMPAGNE METAL FINISH FOR APPROVAL
2. FABRIC FOR APPROVAL

ISSUE ISSUE DATE

REVISION REVISION DATE
 PROJECT PROJECT NO. 07036

PARK HYATT - CARNEGIE
57TH STREET BLDG.
 WEST 57TH STREET
 NEW YORK, NEW YORK 10019

DRAWING DRAWING NO.
HOT-500-LT

GUEST ROOMS 1 OF 1

FLOOR LAMP

SCALE DATE
 AS NOTED 11.04.2011
 DRAWN BY CHECKED BY
 RA



2 DETAIL
 N.T.S.



3 DETAIL
 TOP AND BOTTOM SHADE
 IMAGE REFERENCE

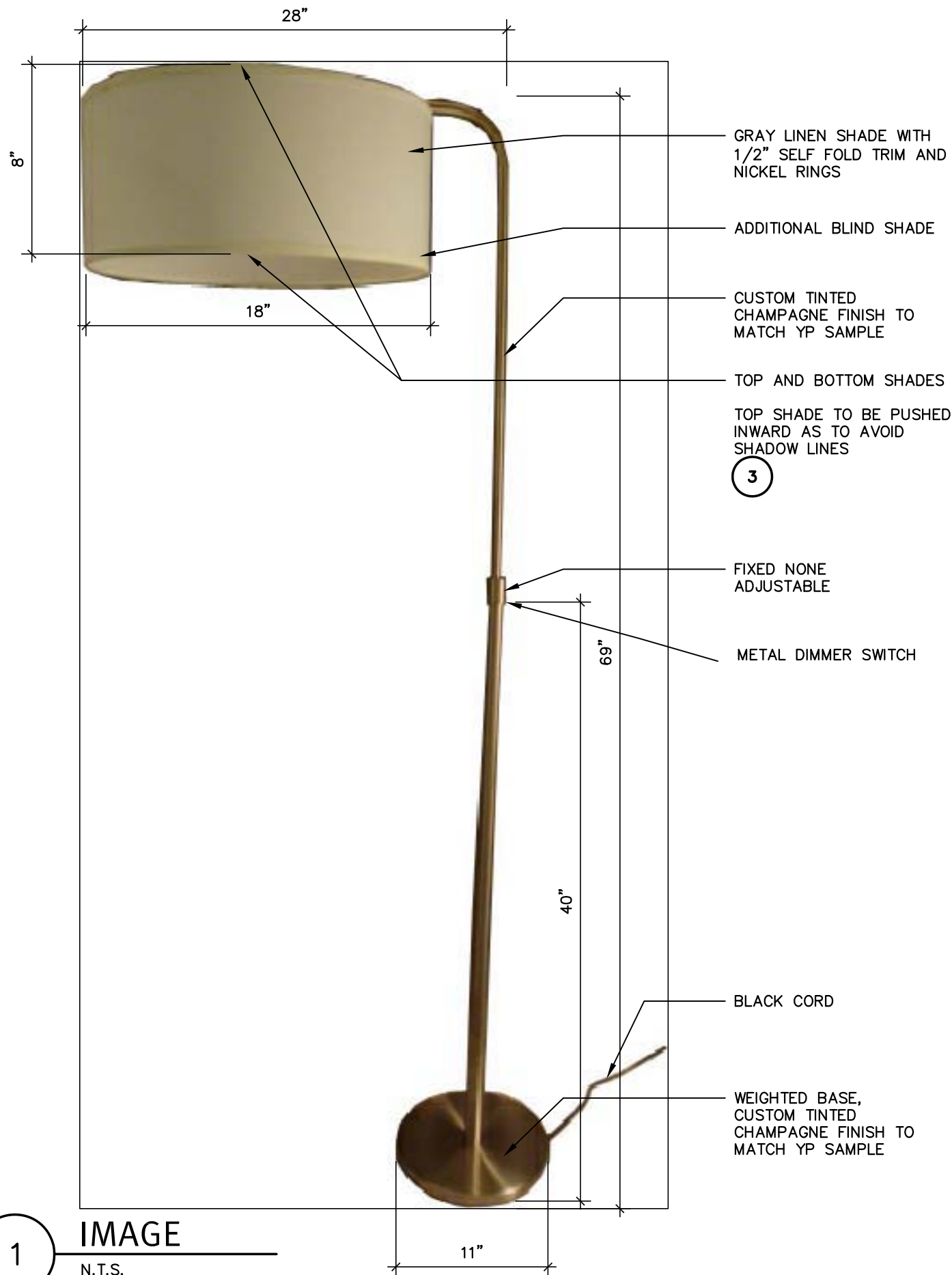

1 IMAGE
 N.T.S.

Secret Desk

Markus Schmidt, 2010



OVERVIEW

Eco-friendly Davenport desk in solid wood with two storage units that lay flush with the table top. Expertly crafted, meticulously smoothed and finished with the finest natural oils, products by Zeitraum exude an unmistakable sense of quality and natural style.

- Structure in solid ash, knotty oak, American cherry, American walnut or European walnut.
- Storage units are deep enough to hold two laptops and include a stationary tray and wire management outlet.
- 55.1" w 33.5" d 29.5" h.
- Custom sizes and timbers available upon request.
- Made in Germany by Zeitraum.
- Warranty: 2 Years against manufacturing defects

ADD TO BINDER

REQUEST QUOTE

EMAIL PRINT SHARE

SUITE SUPPORT

Many of our products come in additional finishes and sizes. For questions, finish options and custom orders please contact showroomsales@suiteny.com or call 1-877-278-4836 Monday-Friday, 9am-6pm to speak to a design expert for advice and consultation.

VIEW LARGER

rollover over image to zoom



TOP OF PAGE



VIEW LARGER

rollover over image to zoom

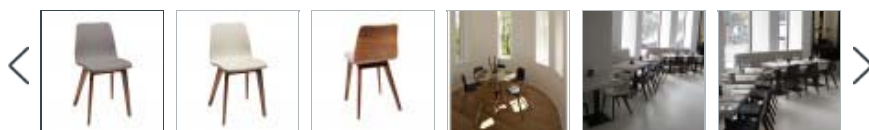

Morph Chair - Upholstered

Formstelle, 2009

\$1,122.00

OVERVIEW

Formstelle was established in 2001 by Claudia Kleine and Jorg Kurschner who work on projects in the fields of interior design, product design and corporate identity with an emphasis on the relationship between space and content coupled with the highest standards of conceptual, technical and design quality. The sculptural Morph chair, 2009, has a frame and four-legged base in solid walnut and a solid molded veneer light-weight wood shell. The unique positioning of the legs creates an interplay of stability and dynamism allowing for maximum comfort while taking up minimum space. All woods are unique and individually selected for color and grain. Further, all woods come from renewable forests that comply with the FSC standard and have no chemical treatments.

DETAILS

- Legs and frame in solid walnut with natural oil finish, front upholstered solid wood molded veneer seat/shell.
- 17.3"w 18.9"d 31.5"h 19.1" seat height
- Kvadrat Hot fabric: 75% cotton 25% viscose teflon. Available in gray and beige-gray.
- Made in Germany by Zeitraum
- Warranty: 2 Years against manufacturing defects.
- No assembly required
- Frame also available in solid oak. Shell also available in veneered oak, veneered walnut, glazed light gray, glazed anthracite and front or fully upholstered in various fabrics and leather, COM or COL. Shell and frame also available in various color stains including chalk, light warm gray, cold gray, dark warm gray, graphite gray, graphite black, aqua blue, mint blue

SHIPPING INFO

EMAIL PRINT SHARE

SUITE SUPPORT

Many of our products come in additional finishes and sizes. For questions, finish options and custom orders please contact showroomsales@suiteny.com or call 1-877-278-4836 Monday-Friday, 9am-6pm to speak to a design

Project Name: **PARK HYATT / CARNEGIE- NYC**
 Project #: **07036**
 Issue Date: **08/31/2009**
 Revision(s): **09/30/2011** Δ 1
New Item

Item Number: **HOT-502-LT**
 Item Description: **Desk Lamp- NT702**
 Area Name: **Hotel Room**

Item Quantity:

Manufacturer: Nessen (YPNY)

Source: A & D Projects Inc.

Address:

Address: 500 West 43rd Street
 Suite #12G
 New York NY 10036-

Phone:

Phone: (732) 450-9791

Fax:

Fax: (732) 450-9793 Mobile: (917) 826-6362

Contact:

Contact:

E-mail:

E-mail: designgrp@aol.com

Web:

Web: www.nessenlighting.com

Model Number: NT702
 Model Name: 14" Swing-Arm Desk Lamp
 Dimensions: 10" x 2-7/8"W x 2"H
 Finish: Polished Chrome
 Switch Type: On/off switch on upright tube, plug-in ballast
 Cord Color: Black
 Lamp Type: Incandescent
 Lamp Wattage: 60W
 Lamp Quantity: 1
 UL Listing: UL Listed
 Shade/Diffuser Style: Arm swings 340 degrees at elbow
 Notes: Lamp to have dimmer switch.



Required Item(s) for Designer Approval Prior to Fabrication:

Prepared By: MR

<input type="checkbox"/> Seaming Diagram	<input type="checkbox"/> Strike-Off	<input checked="" type="checkbox"/> Finish Sample	<input type="checkbox"/> Cutting	<input type="checkbox"/> Shop Dwgs	<input type="checkbox"/> Prototype	<input type="checkbox"/> Flame Certificate
--	-------------------------------------	---	----------------------------------	------------------------------------	------------------------------------	--

Instructions:

- 1 Cords are to be a minimum of 2440 mm (8'-0" long), unless noted otherwise. Cords shall be insulated and grounded.
- 2 Lamps will have a weighted base to ensure stability & will have felt bottoms or other non-marking material.
- 3 Pendants and or flush mounted fixtures must be hard wired to an electrical J-box and activated by a wall switch or the dimming system.
- 4 Purchasing Agent is responsible for ensuring fixture complies with local power supply and local codes.
- 5 Purchasing Agent is responsible for supplying all lamps for specified fixtures.

Project Name: **PARK HYATT / CARNEGIE- NYC**
 Project #: **07036**
 Issue Date: **08/31/2009**
 Revision(s): **09/30/2011** Δ 3
New Notes and Drawing

Item Number: **HOT-417A-CG**
 Item Description: **TV Credenza- Custom- 5'-6"**
 Area Name: **Hotel Room**

Item Quantity:

Manufacturer: By Millwork Contractor
 Address:

Source: By Millwork Contractor
 Address:

Phone:

Phone:

Fax:

Fax:

Contact:

Contact:

E-mail:

E-mail:

Web:

Web:

Description: Custom TV Credenza - 5'-6"
 Refer to drawing HOT-417A&B&C-CG for design details

Finish References: ML-01 Plated Finish / Brass Substrate -
 WD-28 Polyester Lacquer / 100% High Gloss /
 Carbon Copy / BM2117-10 / 1 -
 MR--17 Bronze Satin Mirror w/ Enduroshield
 protective coating -

Notes: Location= Guestrooms

Required Item(s) for Designer Approval Prior to Fabrication:

Prepared By: CG

<input type="checkbox"/> Seaming Diagram	<input type="checkbox"/> Strike-Off	<input checked="" type="checkbox"/> Finish Sample	<input type="checkbox"/> Cutting	<input checked="" type="checkbox"/> Shop Dwgs	<input type="checkbox"/> Prototype	<input type="checkbox"/> Flame Certificate
--	-------------------------------------	---	----------------------------------	---	------------------------------------	--

Instructions:

- 1 Any materials used must be suitable for use in location specified and varying climatic situations.
- 2 All work is to be corner blocked, well fitted, double doweled, glued, and screwed into place. Joint glue must be of the best quality and any excess glue will be thoroughly cleaned.
- 3 All items are to be mill fabricated according to the size and design indicated on the approved shop drawings.
- 4 Legs and bases must be made of wood solids.
- 5 All drawer fronts will be as specified and should be made of lumber or veneer plywood.
- 6 Drawer sides, backs and sub fronts will be made of 13 mm (1/2") solid lumber or veneered plywood.

Project Name: **PARK HYATT / CARNEGIE- NYC**
 Project #: **07036**
 Issue Date: **08/31/2009**
 Revision(s): **09/30/2011** Δ 3

Item Number: **HOT-417A-CG**
 Item Description: **TV Credenza- Custom- 5'-6"**
 Area Name: **Hotel Room**

Item Quantity:

Manufacturer: By Millwork Contractor
 Address:

Source: By Millwork Contractor
 Address:

Phone:

Phone:

Fax:

Fax:

Contact:

Contact:

E-mail:

E-mail:

Web:

Web:

Instructions:

- 7 Drawer bottoms will be made of solid lumber or veneered plywood. Drawer bottoms may not be made of Masonite or particleboard.
- 8 Drawer sides will be dovetailed or butterfly jointed and glued under pressure. The dovetails will be milled true and even.
- 9 Drawer and door interiors must be veneered and finished to match the exterior of the unit.
- 10 Drawer and door interiors will be sanded smooth, lacquered and waxed.
- 11 All drawers will have a stop mechanism that is removable when required for repairs or access.
- 12 All cabinet doors will be as specified and should be made of 19 mm (3/4") lumber or veneered plywood or as required.
- 13 Cabinet door interiors must be veneered and finished to match the exterior of the unit.
- 14 All adjustable shelving will be made of solid wood or veneered plywood unless otherwise specified.
- 15 For all shelves, the top, bottom, and side edges must match the exterior of the unit.
- 16 All casegood hardware and accessories will be furnished and installed by the vendor and must be indicated on the shop drawings.
- 17 All drawers and pull out shelves will have concealed, undermounted hardware. Full extension, metal drawer glides or shelf slides with ball bearing nylon rollers are required. These should be self-closing and have stops.
- 18 All casegood and softgood legs and bases will have self-leveling adjustable nylon contract quality carpet glides, appropriate to the weight of the piece and the floor finish on which the casegood will be placed.
- 19 All glides and levelers will be non-rusting.
- 20 The casegood vendor will supply templates for all glass tops when supplied by others.

GENERAL NOTES

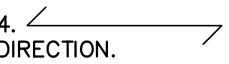
1. ALL METAL TO BE **ML1**
2. ALL WOOD TO BE **WD28**
3. ALL MIRROR TO BE **MR17**
4.  DENOTES WOOD GRAIN DIRECTION.
5. ALL MDF TO BE 3/4" THICK UNLESS NOTED OTHERWISE
6. CONTRACTOR TO PROVIDE LEVELERS

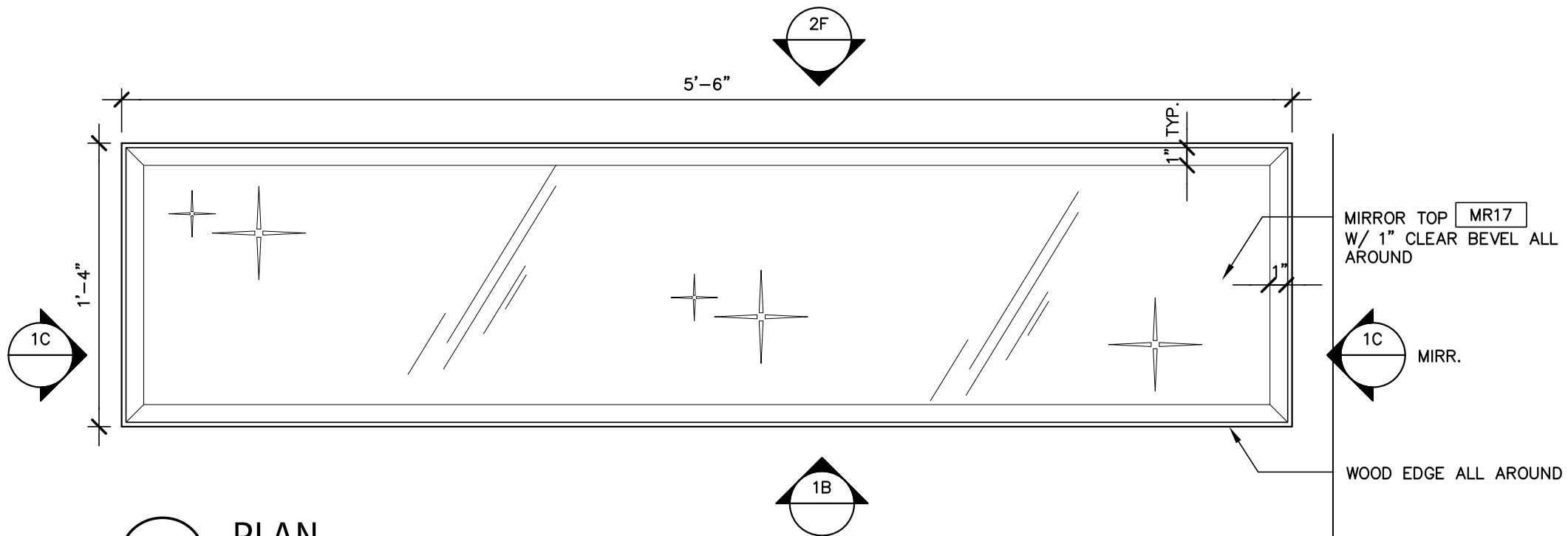

1A PLAN
 SCALE: 1 1/2"=1'-0"

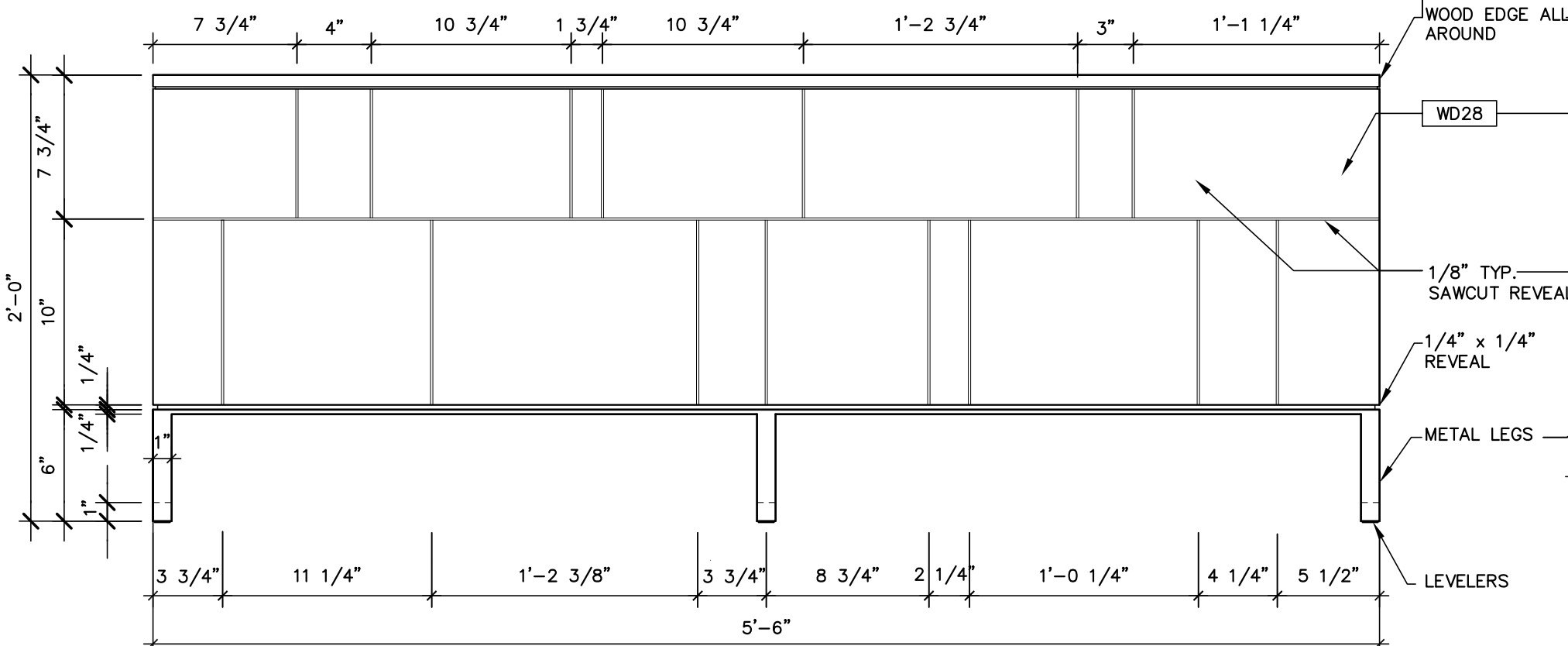

1B FRONT ELEVATION
 SCALE: 1 1/2"=1'-0"

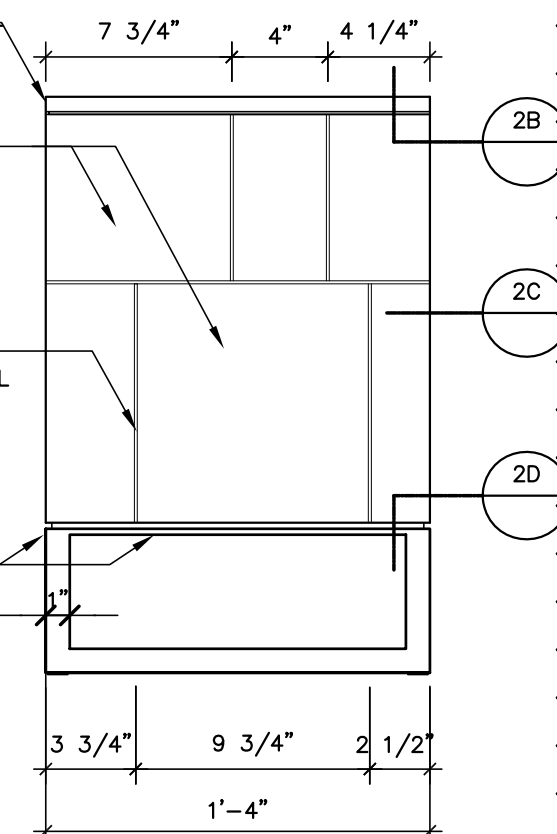

1C SIDE ELEVATION
 SCALE: 1 1/2"=1'-0"

ISSUE	ISSUE DATE

REVISION	REVISION DATE
PROJECT	PROJECT NO. 07036

PARK HYATT - CARNEGIE
 57TH STREET BLDG.
 WEST 57TH STREET
 NEW YORK, NEW YORK 10019

DRAWING	DRAWING NO.
	HOT-417-A-CG

FLOORS 4-18
DOUBLE ROOM
CRENZENZA

SCALE	DATE
AS NOTED	09.30.2011
DRAWN BY	CHECKED BY
AG	

CONTRACTOR MUST CHECK AND VERIFY ALL JOB DIMENSIONS, DRAWINGS, DETAILS AND SPECIFICATIONS REPORT ANY DISCREPANCIES TO DESIGNERS BEFORE PROCEEDING WITH WORK

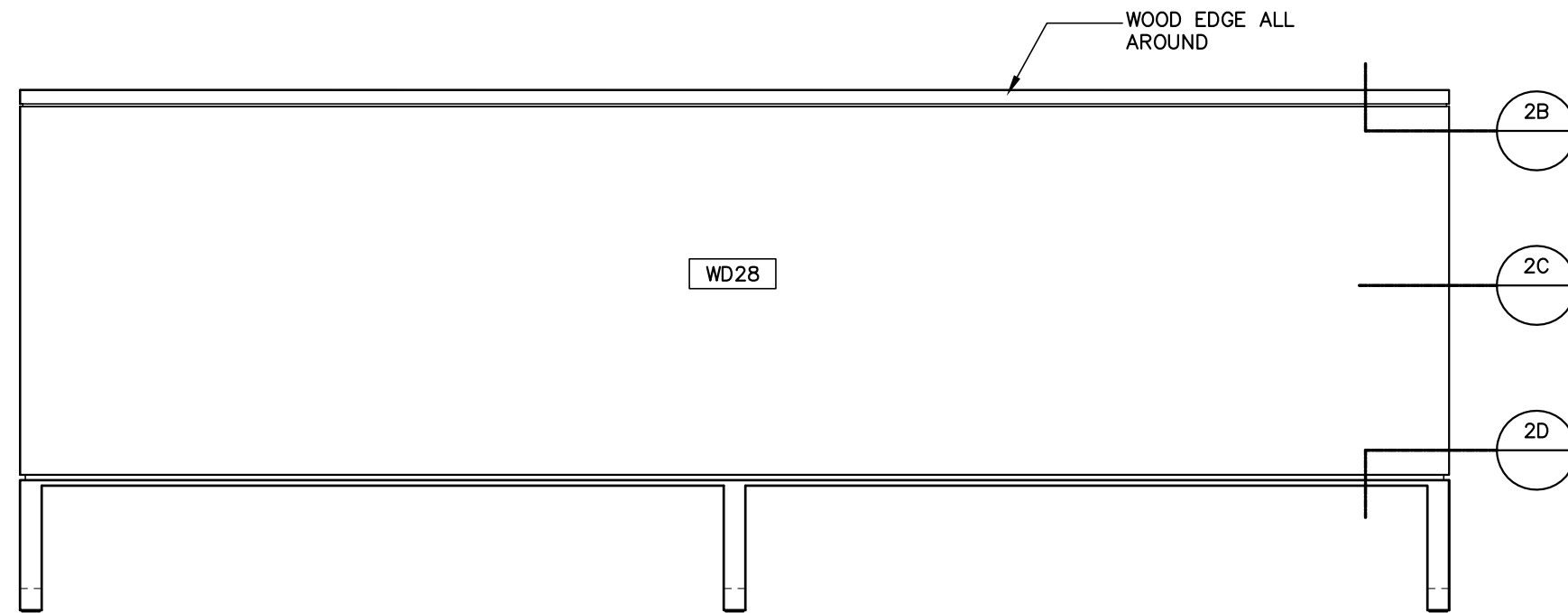

2A BACK ELEVATION
SCALE: 1 1/2"=1'-0"

GENERAL NOTES

1. ALL METAL TO BE **ML1**
2. ALL WOOD TO BE **WD28**
3. ALL MIRROR TO BE **MR17**
4. DENOTES WOOD GRAIN DIRECTION.
5. ALL MDF TO BE 3/4" THICK UNLESS NOTED OTHERWISE
6. CONTRACTOR TO PROVIDE LEVELERS

ISSUE	ISSUE DATE

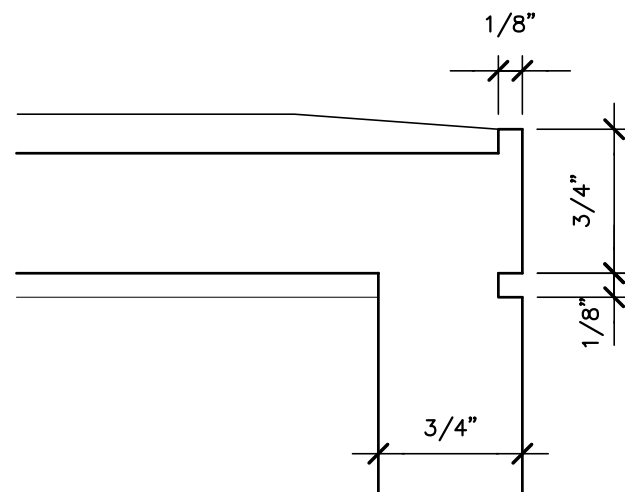

2B SECTION DETAIL
SCALE: FULL SCALE

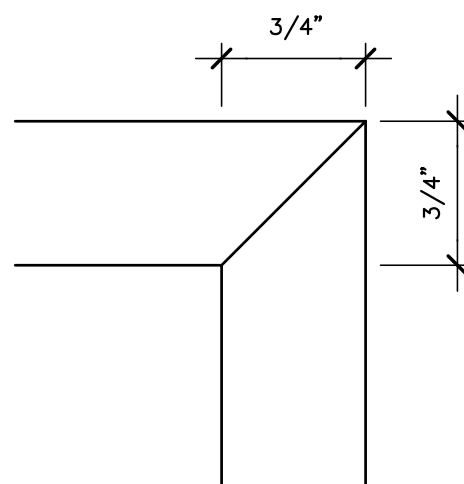

2C PLAN DETAIL
SCALE: FULL SCALE

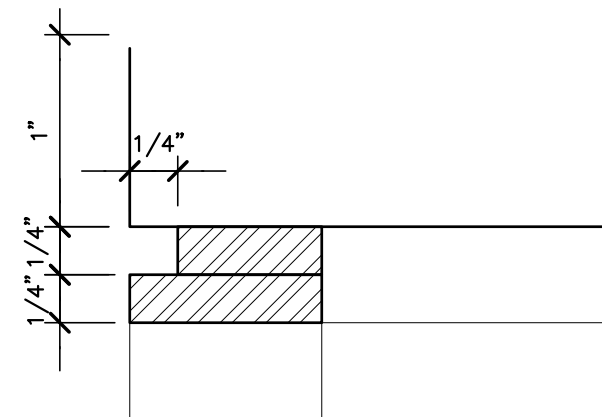

2D LEG SECTION DETAIL
SCALE: FULL SCALE

REVISION	REVISION DATE

PROJECT PROJECT NO. 07036
PARK HYATT - CARNEGIE
57TH STREET BLDG.
WEST 57TH STREET
NEW YORK, NEW YORK 10019

DRAWING DRAWING NO.
HOT-417-A-CG
2 OF 2

FLOORS 4-18
DOUBLE ROOM
CREDENZA

SCALE	DATE
AS NOTED	07.22.2011
DRAWN BY	CHECKED BY
AG	



Desks & chairs



LUGO DESK MATTE WHITE
H 29-3/4", W 55-1/4", D 31-1/2"



Make this piece fit your needs!

Our desks and chairs offer customization options so you can make it right for your home.

[Design in 3D](#)

Features

- our desks and chairs come in a variety of colors and a choice of bases
- go with our 'all-in-one' desk with integrated Bluetooth enabled speakers and storage space as well as easy cable management

Delivery

Our customizable desks and chairs are produced upon order. Delivery times may vary, please contact your local [store](#) for more details.

Materials

- our board furniture is mainly made of particle board. However, MDF (medium density fibreboard) is primarily used for furniture with organic shapes
- our veneers have a coating of lacquer to make a more smooth and longlasting finish. The lacquers we use are mainly waterbased so they have a strictly limited impact on the environment
- all veneers come from North American plantations

Care instructions

- wipe clean with a cloth dampened in a mild cleaner
- wipe dry with a clean cloth

[Get more instructions](#)

[Send your idea to the BoConcept idea box](#)



[SHOP](#)

[MATTER-MADE](#)

[BLOG](#)

[CONTACT](#)

[PRESS](#)

[ABOUT](#)

[LOGIN](#)



ENTER YOUR QUERY

[HOME](#) › [SEATING](#) › [ALL](#) › [CROSS CHAIR - BLACK WALNUT UPHOLSTERED](#)



ITEM:
CROSS CHAIR - BLACK WALNUT UPHOLSTERED

DESIGNER:
DAVID IRWIN

MANUFACTURER:
JUNIPER

MATERIALS:
AMERICAN BLACK WALNUT,
FABRIC UPHOLSTERY

DIMENSIONS:
W 20" x D 20" x H 31"
Seat H 17"

DESCRIPTION:
The concept behind the Cross Chair was to pare back the structure to it's minimum requirement whilst retaining an elegant form. This allowed us to focus on the high quality of materials and finish. It's minimal construction consists of two interlocking profiles, which take their cue from the symmetrical nature of an hourglass. It's unique form makes it possible to neatly stack multiple Cross Chairs saving space while preserving it's aesthetic profile. Also available in an unupholstered version.

COLOR:

PRICE:
\$585.00

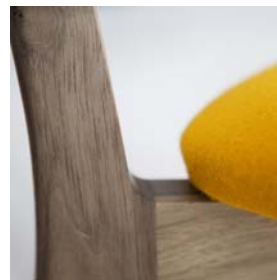



Chests of drawers



Fermo double dresser, available in different colors. Shown color, white lacquer/anthracite gray burnished steel. H39½xW60xD19¾". [Fermo - FA28]

Article no.: 3670096FA281111

\$1,895



Make this chest of drawers fit your needs!

All our chests of drawers can be customized to fit your needs and your home perfectly.

[Design in 3D](#)

Features

- our chests of drawers are customizable and you can choose between different sizes, colors and leg designs
- enjoy our soft close system that comes as standard
- the Global range comes with a choice of handles

Designer

Morten Georgsen



Delivery

Our customizable chests of drawers are produced upon order. Delivery times may vary, please contact your local [store](#) for more details.

Materials

- our board furniture is mainly made of particle board. However, MDF (medium density fibreboard) is primarily used for furniture with organic shapes
- our veneers have a coating of lacquer to make a more smooth and longlasting finish. The lacquers we use are mainly waterbased so they have a strictly limited impact on the environment
- all veneers come from North American plantations