



EMAIL SIGN-UP  
DWR BLOG | DESIGN NOTES  
REQUEST A CATALOG  
DWR 3-D ROOM PLANNER  
TRADE & CONTRACT

ABOUT DWR | DWR LOCATIONS | 800.944.2233 | LIVE CHAT

Enter keyword or Item#

MY ACCOUNT | CUSTOMER SERVICE | CART (1 item) \$4,976.00

[NEW](#) | [LIVING](#) | [DINING](#) | [BEDROOM](#) | [OUTDOOR](#) | [WORKSPACE](#) | [STORAGE](#) | [LIGHTING](#) | [RUGS](#) | [ACCESSORIES](#) | [DESIGNERS](#) | [SALE](#)

Home > Dining > Tables > Saarinen Round Dining Table



VIEW LARGER



### Saarinen Round Dining Table

Designed by Eero Saarinen for Knoll®

In a 1956 Time magazine cover story, Eero Saarinen said that "the underside of typical tables and chairs makes a confusing, unre...[more info](#)

**Saarinen Round Dining Table | Stocked Options #34008**

\$1,935.00 - \$4,976.00 USD



Item:

Status: **INSTOCK**

Quantity:

**Saarinen Round Dining Table | Custom Options #12765**

\$1,935.00 - \$8,383.00 USD

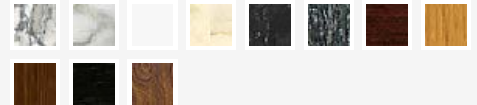

Item:

Status:

Quantity:

ADD TO WISH LIST

ADD TO CART

SHARE WITH YOUR FRIENDS:



YOU MAY ALSO LIKE

SIMILAR PRODUCTS



Saarinen Oval Dining Table  
\$5,081.00 - \$13,260.00 USD

Saarinen Side Table  
\$702.00 - \$1,978.00 USD

Saarinen Tulip™ Armless Chair  
\$1,542.00 - \$1,746.00 USD

Saarinen Tulip™ Arm chair  
\$1,786.00 - \$3,066.00 USD

PRODUCT INFORMATION

DESIGNER

### Product Information

In a 1956 *Time* magazine cover story, Eero Saarinen said that "the underside of typical tables and chairs makes a confusing, unrestful world," and that he was designing a new collection to "clear up the slum of legs in the U.S. home." Later that year, he completed his Pedestal Table (1956), whose form was inspired by a drop of high-viscosity liquid. This iconic table features a cast-aluminum base with abrasion-resistant Rilsan finish and a solid marble, wood veneer or laminate tabletop. Each is stamped with the KnollStudio logo and Eero Saarinen's signature. This is the authentic Saarinen Pedestal Table by Knoll. Base made in China; tabletop made in Italy or U.S.A., depending on material.

- Stone masters carefully select marble with the best composition and veining to create tops for marble Saarinen Pedestal Tables. Please rest assured that each one's unique markings are not imperfections but rather the very traits that make it a true one of a kind.
- Coated marble tops have a glossy polyester coating, and satin-coated marble tops have a matte satin polyester coating; both types help protect against stains.

### Materials

Cast-aluminum base with Rilsan® finish; solid marble, wood veneer or laminate tabletop with beveled edge.

Solid marble: Arabescato (white with heavy grey veining), Calacatta, Nero Marquina, Verde Alpi (green with black and white veining) or Extra-White (pure white with very faint traces of grey).

Wood veneer: MDF with cathedral-grain oak, walnut, cherry, ebonized walnut or Pau Ferro rosewood veneer.

Laminate: MDF with laminate.

### Measurements

H 28.25" Diameter 35", 42", 47", 54" or 60"

### Care and Assembly

[Assembly Instructions](#)

### Shipping Info

Due to size, weight and fragility, marble tables must ship with our White Glove Service. For all other tables, you can select the delivery option that best meets your needs during checkout. [View delivery options.](#)

#### SIGN UP FOR EMAILS

Be the first to know about DWR special offers, new product launches and Studio events.

**SUBMIT**

#### JOIN THE CONVERSATION

[facebook](#) [twitter](#) [Pinterest](#) [houzz](#)

#### CUSTOMER SERVICE

- Contact Us
- Shipping Information
- Returns & Exchanges
- FAQ
- Privacy and Security

#### DWR QUICKLINKS

- My Account
- Gift Card
- DWR Credit Card
- Trade & Contract Sales
- Manufacturers
- Videos
- Resource Center
- Designers

#### CORPORATE INFO

- About Us
- Press
- Careers
- Terms of Use
- Affiliate Program
- Site Map



#### CATALOG SIGN-UP

Receive free monthly catalogs showcasing the best in modern design.

[▶ REQUEST THE LATEST CATALOG](#)



EMAIL SIGN-UP  
DWR BLOG | DESIGN NOTES  
REQUEST A CATALOG  
DWR 3-D ROOM PLANNER  
TRADE & CONTRACT

ABOUT DWR | DWR LOCATIONS | 800.944.2233 | LIVE CHAT

Enter keyword or Item#

MY ACCOUNT | CUSTOMER SERVICE | CART (1 item) \$4,976.00

[NEW](#) | [LIVING](#) | [DINING](#) | [BEDROOM](#) | [OUTDOOR](#) | [WORKSPACE](#) | [STORAGE](#) | [LIGHTING](#) | [RUGS](#) | [ACCESSORIES](#) | [DESIGNERS](#) | [SALE](#)

Home > Designers > R-U > Eero Saarinen > Saarinen Executive Side Chair with Metal Legs in Leather



[VIEW LARGER](#)



### Saarinen Executive Side Chair with Metal Legs in Leather

*Designed by Eero Saarinen for Knoll®*

The design of Eero Saarinen's Executive Side Chair (1946) began more than a decade earlier, when he and Charles Eames submitted [...more info](#)

**Saarinen Executive Chair Metal - Volo Leather #11441**

\$1,616.00 USD

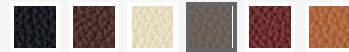

Item:

Status: **7-9 WEEKS**

Quantity:

[ADD TO WISH LIST](#)

[ADD TO CART](#)

SHARE WITH YOUR FRIENDS:



YOU MAY ALSO LIKE

SIMILAR PRODUCTS

RECENTLY VIEWED



Saarinen Executive Armchair with Metal Legs in Fabric

\$1,553.00 - \$1,685.00 USD

Saarinen Executive Armchair - Wood Legs

\$1,802.00 - \$2,812.00 USD

Saarinen Executive Armchair with Casters

\$2,067.00 - \$3,067.00 USD

Saarinen Executive Armchair with Metal Legs - Leather

\$2,550.00 USD

PRODUCT INFORMATION

DESIGNER

### Product Information

The design of Eero Saarinen's Executive Side Chair (1946) began more than a decade earlier, when he and Charles Eames submitted several designs to the Organic Design in Home Furnishings competition at the MoMA. The pair, who'd been friends and collaborators since meeting at Cranbrook Academy of Art, won first prize. These fluid, sculptural shapes influenced the future work of both men; for Saarinen, most notably in his Womb, Tulip and Executive chairs. The Executive was originally made of fiberglass but was later updated in polyurethane to take advantage of the technical advances in plastics. The feel of this classic seat, however, remains unchanged. The molded shell flexes slightly with the sitter and the contoured plywood seat supported by metal or wood legs. Unlike Saarinen's furniture, which was consistently sculptural in form, these fluid lines didn't appear in his architecture until the 1950s. When looking at the dome-shaped glass wall of the Kresge Auditorium at MIT, it's not a big leap to see the same shape in the back of his Executive Chair. This chair is Greenguard Indoor Air Quality Certified; for its use of low-emitting products. Manufactured by Knoll® according to the original and exacting specifications of the designer. Made in U.S.A.

### Materials

Molded reinforced polyurethane shell; contoured plywood seat; steel leg base; seamless tubular steel legs with polished chrome finish; Spinneybeck Volo leather upholstery.

### Measurements

H 31.5" W 24.25" D 20.5" Seat H 18.75"

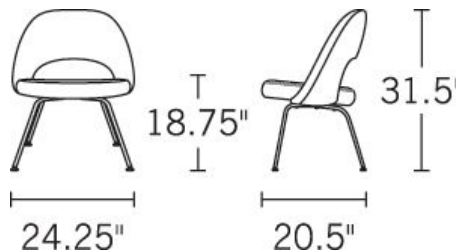

### Shipping Info

Ships via Standard Service.  
[View delivery options.](#)

### SIGN UP FOR EMAILS

Be the first to know about DWR special offers, new product launches and Studio events.



**SUBMIT**

### JOIN THE CONVERSATION

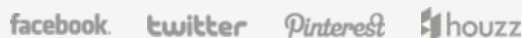

#### CUSTOMER SERVICE

- Contact Us
- Shipping Information
- Returns & Exchanges
- FAQ
- Privacy and Security

#### DWR QUICKLINKS

- My Account
- Gift Card
- DWR Credit Card
- Trade & Contract Sales
- Manufacturers
- Videos
- Resource Center
- Designers

#### CORPORATE INFO

- About Us
- Press
- Careers
- Terms of Use
- Affiliate Program
- Site Map



#### CATALOG SIGN-UP

Receive free monthly catalogs showcasing the best in modern design.  
 ▶ **REQUEST THE LATEST CATALOG**

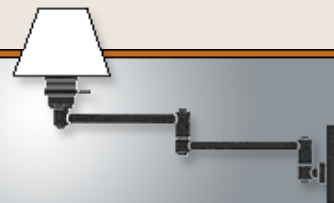

Thursday, August 28, 2014

[Table](#) | [Wall](#) | [Floor](#) | **[Pendant & Ceiling](#)** | [Specialty](#) | [Archive](#) [PDF downloads](#) | [Order a Nessen Binder](#) | [GSA](#)

[Home](#)

**PRODUCTS**

[About](#)

[Contact](#)

[Rep List](#)

[Price List](#)

[Find a Fixture](#)

[Designers](#)

[Photos](#)



## ELLEN PENDANT LAMP

download PDF 

### NH826

Solid brass, 5" diam. canopy with hang straight. For ceiling box mounting. Two sockets controlled by separate wall switch. 100W max. each or appropriate cfl lamping. ULcUL listed.

#### SPECIFICATIONS:

##### Finishes:

Standard Metal Finishes:  
Polished Brass, Brushed Brass,  
Antique Brass, Polished Chrome,  
Satin Chrome, Polished Nickel,  
Satin Nickel

##### Optional Finishes:

Baked Enamel Paint

##### Shades:

Outer Shade: Titanium  
Inner Shade: Ivory Silk Pongee  
*See other standard shades below. Custom fabrics may be special ordered - please contact your Nessen representative.*

##### Shade Dimensions:

Outer Shade: B 24", T 24", H 6"  
Inner Shade: B 20", T 20", H 10"

##### Related Items:

##### Designed by:

Wooding Design, Ltd.

For modifications and special contract orders, see [price list](#) or [contact](#) your Nessen representative



[click to enlarge](#)

Dimensions:

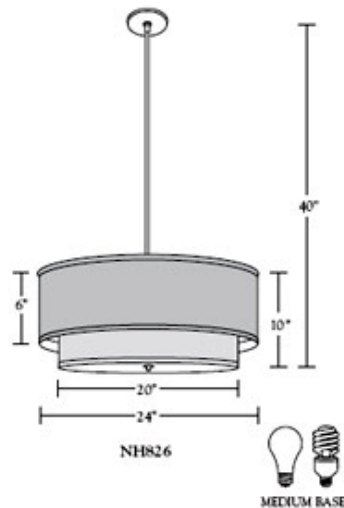

Photometrics:

no photometric data currently available

**Need some help?**  
Call us: (914) 698-7799  
[www.nessenlighting.com](http://www.nessenlighting.com)



## Aiden and Aiden II

Jeff Vioski

### OVERVIEW

storage and a smart, orderly appearance.

- Available in flat cut or quarter cut walnut with matte natural finish, macassar ebony with matte natural finish, zebrawood with matte natural finish or rift cut white oak with matte espresso finish or matte natural finish. Also available lacquered in matte white, gray or black.
- 4-Leg metal base available in satin chrome, matte black or matte bronze finish.
- Aiden I: 68.0"w 16.0"d 32.0"h
- Aiden II: 84.0"w 16.0"d 28.0"h
- Made in USA by Vioski.
- Additional options include a polyurethane finish on all woods except for lacquer and metal base in polished chrome finish.

VIEW LARGER

rollover over image to zoom



ADD TO BINDER

REQUEST QUOTE

EMAIL PRINT SHARE

### SUITE SUPPORT

Many of our products come in additional finishes and sizes. For questions, finish options and custom orders please contact [showroomsales@suiteny.com](mailto:showroomsales@suiteny.com) or call 1-877-278-4836 Monday-Friday, 9am-6pm to speak to a design expert for advice and consultation.

TOP OF PAGE

QUICKSHIP

DINING LIVING WORKSPACE BEDROOM OUTDOOR LIGHTING ACCESSORIES PROJECTS

SUITE NEWS

Home / Hampton Sofa

## Hampton Sofa

CRD Verzelloni, 2011

\$7,190.00

### OVERVIEW

Hampton is an elegant and refined two-seater sofa, a real modern reformulation of classic sofa design. The arm is the same depth as the sofa and seat cushions are parallel to the entire length of the sofa; thus highlighting its symmetry, square shape and simple, harmonious lines. An elegant bridge foot cast in burnished aluminum gives the sofa a visual lightness.

### DETAILS

### SHIPPING INFO

EMAIL PRINT SHARE

### SUITE SUPPORT

Many of our products come in additional finishes and sizes. For questions, finish options and custom orders please contact [showroomsales@suiteny.com](mailto:showroomsales@suiteny.com) or call 1-877-278-4836 Monday-Friday, 9am-6pm to speak to a design expert for advice and consultation.



VIEW LARGER

rollover over image to zoom



## PRODUCT OPTIONS



23001 - Hampton Sofa - Sand  
\$ 7,190.00



VIEW LARGER

QUANTITY 1

ADD TO CART

ADD TO BINDER

WHITE GLOVE

**HAMPTON VERSIONE A**

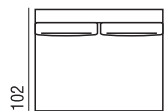

136

**ELEMENTO 136 A**

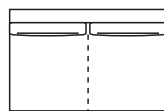

167

**ELEMENTO 167 A**  
cuscino unico/cuscini divisi

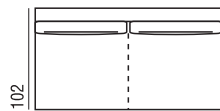

198

**ELEMENTO 198 A**  
cuscino unico/cuscini divisi

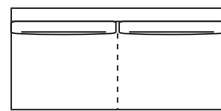

226

**ELEMENTO 226 A**  
cuscino unico/cuscini divisi

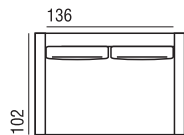

156

**DIVANO 156 A**

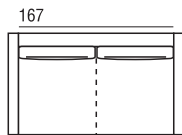

187

**DIVANO 187 A**  
cuscino unico/cuscini divisi

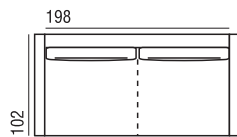

218

**DIVANO 218 A**  
cuscino unico/cuscini divisi

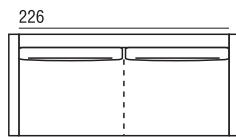

246

**DIVANO 246 A**  
cuscino unico/cuscini divisi

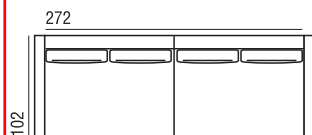

292

**DIVANO 292 A**  
composto da 2 laterali 146 SX e DX

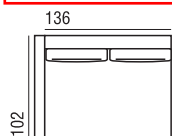

146

**LATERALE 146 SX A**

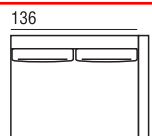

146

**LATERALE 146 DX A**

**HAMPTON VERSIONE B**

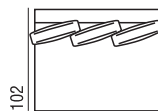

136

**ELEMENTO 136 B**

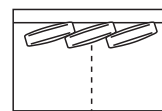

167

**ELEMENTO 167 B**  
cuscino unico/cuscini divisi

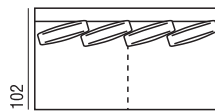

198

**ELEMENTO 198 B**  
cuscino unico/cuscini divisi

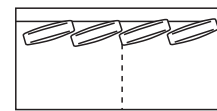

226

**ELEMENTO 226 B**  
cuscino unico/cuscini divisi

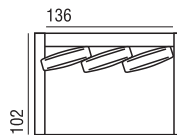

156

**DIVANO 156 B**

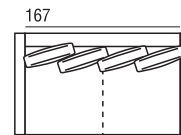

187

**DIVANO 187 B**  
cuscino unico/cuscini divisi

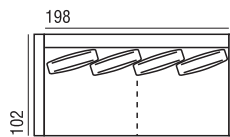

218

**DIVANO 218 B**  
cuscino unico/cuscini divisi

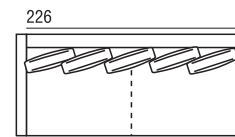

246

**DIVANO 246 B**  
cuscino unico/cuscini divisi

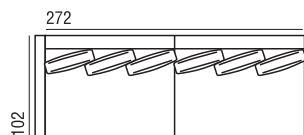

292

**DIVANO 292 B**  
composto da 2 laterali 146 SX e DX

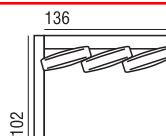

146

**LATERALE 146 SX B**

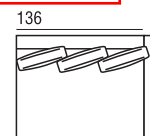

146

**LATERALE 146 DX B**





## HAMPTON VERSIONE A



87

87

POLTRONA 87 A



79

87

FIANCO

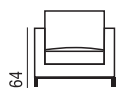

64

87

FRONTE

## HAMPTON VERSIONE B

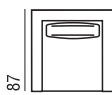

87

87

POLTRONA 87 B



79

87

FIANCO



64

87

FRONTE

## COMPLEMENTI



41

FIANCO POUF



102

POUF 102x102



70

POUF 70x102



80

POUF 120x80



65

SCHIENALE  
65x65

57

SCHIENALE  
57x57 (tipo B)

48

SCHIENALE  
48x48

45

CUSCINO  
45x45

41

CUSCINO  
41x41

33

CUSCINO  
54x33

25

86

CUSCINO  
POGGIARENI 86

25

72

CUSCINO  
POGGIARENI 72

25

56

CUSCINO  
POGGIARENI 56

25

40

CUSCINO  
POGGIARENI 40

### TAVOLINO ARGO

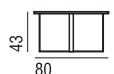

43

80

FRONTE

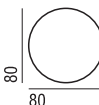

80

80

PIANTA

### TAVOLINO JIM



43

42

FIANCO



43

50

FRONTE



43

50

PIANTA

### BLOG TAVOLINO ROTONDO



41

14

44

FRONTE



41

43

FIANCO



14

ø 44

PIANTA

### BLOG TAVOLINO RETTANGOLARE



41

14

44

FRONTE



41

34

FIANCO



34

44

PIANTA

YABUPUSHELBERG

Project Name: **PARK HYATT / CARNEGIE- NYC**  
Project #: **07036**  
Issue Date: **08/31/2009**  
Revision(s): **03/27/2012** Δ 1  
New Product

Item Number: **HOT-420-CG**  
Item Description: **Side Table- Custom to Bid**  
Area Name: **Hotel Room**

Item Quantity:

Manufacturer: By Custom Furniture Manufacturer  
Address:  
Phone:  
Fax:  
Contact:  
E-mail:  
Web:

Source: By Custom Furniture Manufacturer  
Address:  
Phone:  
Fax:  
Contact:  
E-mail:  
Web:

Description: Side Table- Custom to Bid  
Width: 37cm  
Depth: 37cm  
Height: 60cm  
Top Mat'l/Finish: Brown Glossy Lacquer  
Base Mat'l/Finish: Glossy Black Nickel

Notes: Lcoation= Suites



Required Item(s) for Designer Approval Prior to Fabrication:

Prepared By: CG

Seaming Diagram     Strike-Off     Finish Sample     Cutting     Shop Dwgs     Prototype     Flame Certificate

Instructions:

- 1 Any materials used must be suitable for use in location specified and varying climatic situations.
- 2 All work is to be corner blocked, well fitted, double doweled, glued, and screwed into place. Joint glue must be of the best quality and any excess glue will be thoroughly cleaned.
- 3 All items are to be mill fabricated according to the size and design indicated on the approved shop drawings.
- 4 Legs and bases must be made of wood solids.
- 5 All drawer fronts will be as specified and should be made of lumber or veneer plywood.
- 6 Drawer sides, backs and sub fronts will be made of 13 mm (1/2") solid lumber or veneered plywood.

QUICKSHIP

DINING LIVING WORKSPACE BEDROOM OUTDOOR LIGHTING ACCESSORIES PROJECTS

SUITE NEWS

## LIVING

Living / Floor / Read Noon

PREVIOUS 13 of 17 NEXT



VIEW LARGER

rollover over image to zoom



### Read Noon

El Schmid, 2008

\$2,175.00

#### OVERVIEW

The desire for simplicity and the pleasure found in pure design led to a geometrical abstraction of natural branch forms in in turn, the Read Noon and entire Noon Collection.

Designer El Schmid is originally from Austria, where he was born in 1953. He started working with metal during his apprenticeship as a craftsman. In a second apprenticeship in Munich he became familiar with materials such as brass, bronze and silver and later studied graphic design, in which he obtained a degree with honors in "Corporate Identity Design". Together with his partner in Munich he founded Schmid & Stemann in 1981. In his own master workshop he dedicated 10 years to the creation of individual designer pieces, which influenced the Munich design-scene

#### DETAILS

- Base and stem in black lacquered iron, shade in warm gray textile.
- Base: 22.0"w 17.7"d 63.0"h Shade: 17.7"dia 11.8"h
- Shade textile: Arenal: 75% viscose, 25% polyamide, interior lined with vegetal paper.
- For avoiding electromagnetic pollution READ NOON is earthed.
- Bulb Information (not included): max. Halogen Classic A, ECO 105 W, E 27 alternativ Concentra Spot, R 80 100 W, E 27
- Manufactured in Germany by Zeitraum.
- Warranty: 2 years against manufacturing defects.
- Also available with a white lamitex shade or a textile shade in white or black.
- Care Instructions: Your product arrives with detailed care instructions. If you need more information please

#### SHIPPING INFO

QUANTITY 1

ADD TO BINDER

ADD TO CART



## Mellow

Formstelle, 2010

### OVERVIEW

the back of the headboard add a touch of sophistication and provide essential support for the soft back cushions.

- Solid wood bed available in ash, oak, cherry, American walnut or European walnut. Back element includes laced leather straps and two pillows filled with duck down and foam core.
- Fully removable covers available in elmo-leather, COM or COL.
- Solid wood bed in Twin, Full, Queen, King and California King sizes
- Twin: 40.0"w 86.0"d Full: 55.0"w 86.0"d Queen: 63.0"w 91.0"d King: 78.9"w 91.0"d California King: 74.1"w 95.0"d
- Bedside height: 12.6"h
- Headboard height (without pillows): 25.2"h
- Recommended with a mattress thickness of 4.7"- 5.5"

VIEW LARGER

rollover over image to zoom



ADD TO BINDER

REQUEST QUOTE

EMAIL PRINT SHARE

### SUITE SUPPORT

Many of our products come in additional finishes and sizes. For questions, finish options and custom orders please contact [showroomsales@suiteny.com](mailto:showroomsales@suiteny.com) or call 1-877-278-4836 Monday-Friday, 9am-6pm to speak to a design expert for advice and consultation.

## SUITE NEW YORK RECOMMENDS



Project Name: **PARK HYATT / CARNEGIE- NYC**  
 Project #: **07036**  
 Issue Date: **08/31/2009**  
 Revision(s): **10/26/2012** Δ4  
New Finishes

Item Number: **HOT-404-CG**  
 Item Description: **Bedside Table- Custom**  
 Area Name: **Hotel Room**

Item Quantity:

Manufacturer: By Millwork Contractor	Source: By Millwork Contractor
Address:	Address:
Phone:	Phone:
Fax:	Fax:
Contact:	Contact:
E-mail:	E-mail:
Web:	Web:

Description: Custom Bedside Table  
 Refer to drawing HOT-404-CG for details

Finish References: ML-01 Plated Finish / Brass Substrate -  
 MR--13 NGM Bronze Mirror / 1" Bevel / 1/4" Thick -  
 MR--17 Bronze Satin Mirror w/ Enduroshield protective  
 coating - TOP  
 WD-02 Claro Walnut / Quarter Cut / Oil / Varnish /  
 Hand-rubbed w/ Wax -

Notes: Location= Guestrooms

Required Item(s) for Designer Approval Prior to Fabrication: Prepared By: MR

<input type="checkbox"/> Seaming Diagram	<input type="checkbox"/> Strike-Off	<input checked="" type="checkbox"/> Finish Sample	<input type="checkbox"/> Cutting	<input checked="" type="checkbox"/> Shop Dwgs	<input type="checkbox"/> Prototype	<input type="checkbox"/> Flame Certificate
--	-------------------------------------	---	----------------------------------	---	------------------------------------	--

Instructions:

- 1 Any materials used must be suitable for use in location specified and varying climatic situations.
- 2 All work is to be corner blocked, well fitted, double doweled, glued, and screwed into place. Joint glue must be of the best quality and any excess glue will be thoroughly cleaned.
- 3 All items are to be mill fabricated according to the size and design indicated on the approved shop drawings.
- 4 Legs and bases must be made of wood solids.
- 5 All drawer fronts will be as specified and should be made of lumber or veneer plywood.

Project Name: **PARK HYATT / CARNEGIE- NYC**  
 Project #: **07036**  
 Issue Date: **08/31/2009**  
 Revision(s): **10/26/2012** ▲4

Item Number: **HOT-404-CG**  
 Item Description: **Bedside Table- Custom**  
 Area Name: **Hotel Room**

Item Quantity:

Manufacturer: By Millwork Contractor

Source: By Millwork Contractor

Instructions:

- 6 Drawer sides, backs and sub fronts will be made of 13 mm (1/2") solid lumber or veneered plywood.
- 7 Drawer bottoms will be made of solid lumber or veneered plywood. Drawer bottoms may not be made of Masonite or particleboard.
- 8 Drawer sides will be dovetailed or butterfly jointed and glued under pressure. The dovetails will be milled true and even.
- 9 Drawer and door interiors must be veneered and finished to match the exterior of the unit.
- 10 Drawer and door interiors will be sanded smooth, lacquered and waxed.
- 11 All drawers will have a stop mechanism that is removable when required for repairs or access.
- 12 All cabinet doors will be as specified and should be made of 19 mm (3/4") lumber or veneered plywood or as required.
- 13 Cabinet door interiors must be veneered and finished to match the exterior of the unit.
- 14 All adjustable shelving will be made of solid wood or veneered plywood unless otherwise specified.
- 15 For all shelves, the top, bottom, and side edges must match the exterior of the unit.
- 16 All casegood hardware and accessories will be furnished and installed by the vendor and must be indicated on the shop drawings.
- 17 All drawers and pull out shelves will have concealed, undermounted hardware. Full extension, metal drawer glides or shelf slides with ball bearing nylon rollers are required. These should be self-closing and have stops.
- 18 All casegood and softgood legs and bases will have self-leveling adjustable nylon contract quality carpet glides, appropriate to the weight of the piece and the floor finish on which the casegood will be placed.
- 19 All glides and levelers will be non-rusting.
- 20 The casegood vendor will supply templates for all glass tops when supplied by others.

YABUPUSHELBERG

55 BOOTH AVENUE TORONTO ONTARIO CANADA  
 M4M 2M3 TELEPHONE 416.778.9779 FAX 416.778.9747  
 4F-138 SPRING STREET YORK N.Y. 10012-3854  
 T E L E P H 0212 226.0808 F A X 212.226.0666  
 EMAIL DESIGN@YABUPUSHELBERG.COM

**GENERAL NOTES**

1. ALL MDF TO BE FINISHED WD2
2. DENOTES WOOD GRAIN DIRECTION.
3. ALL METAL TO BE FINISHED ML1
4. ALL MIRROR TO BE FINISHED MR13 UNLESS NOTED OTHERWISE

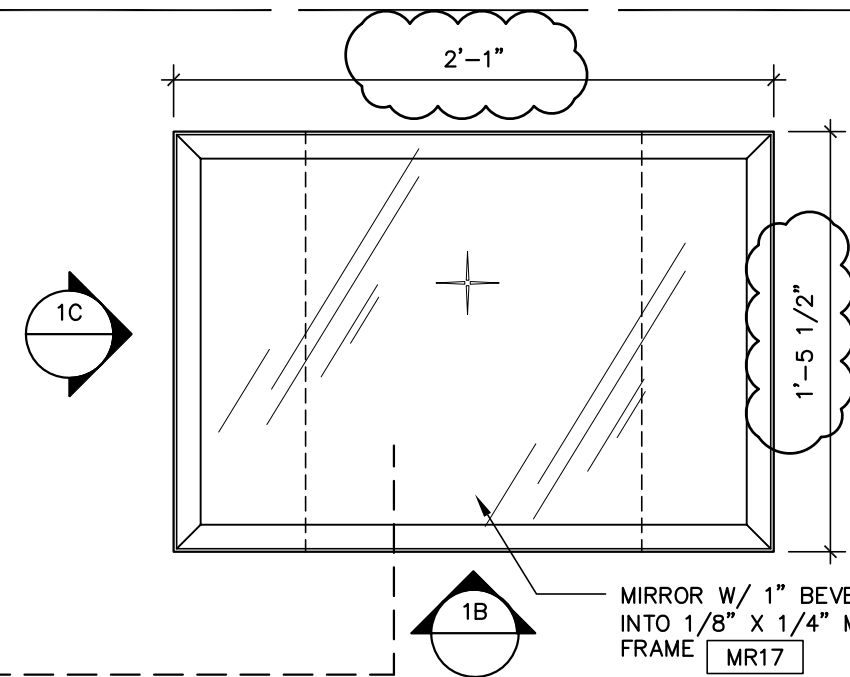

**1A** PLAN  
 SCALE: 1 1/2" = 1'-0"

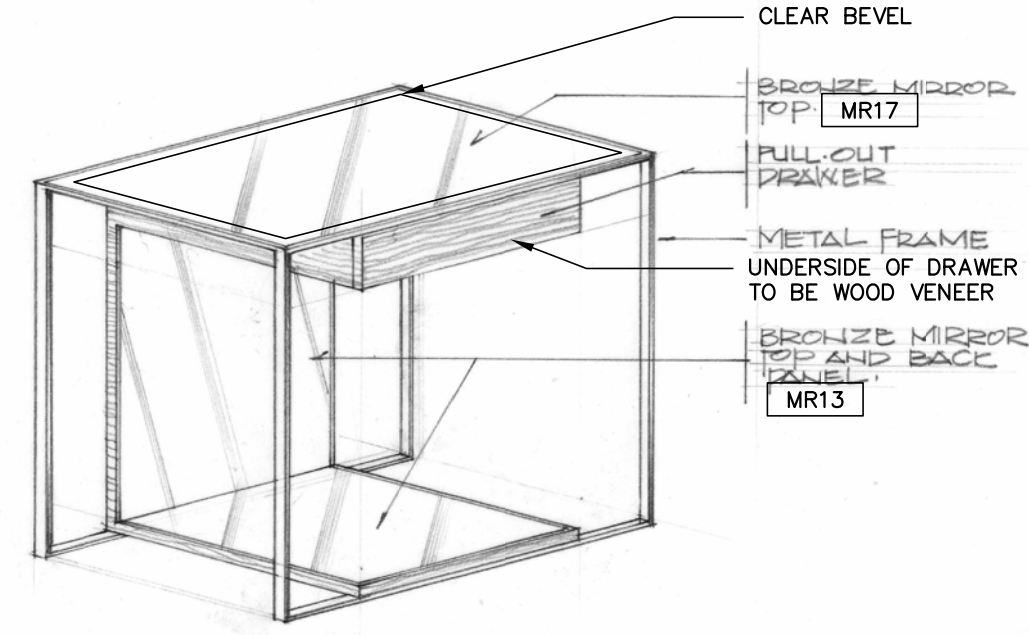

**1D** AXONOMETRIC  
 SCALE: 1 1/2" = 1'-0"

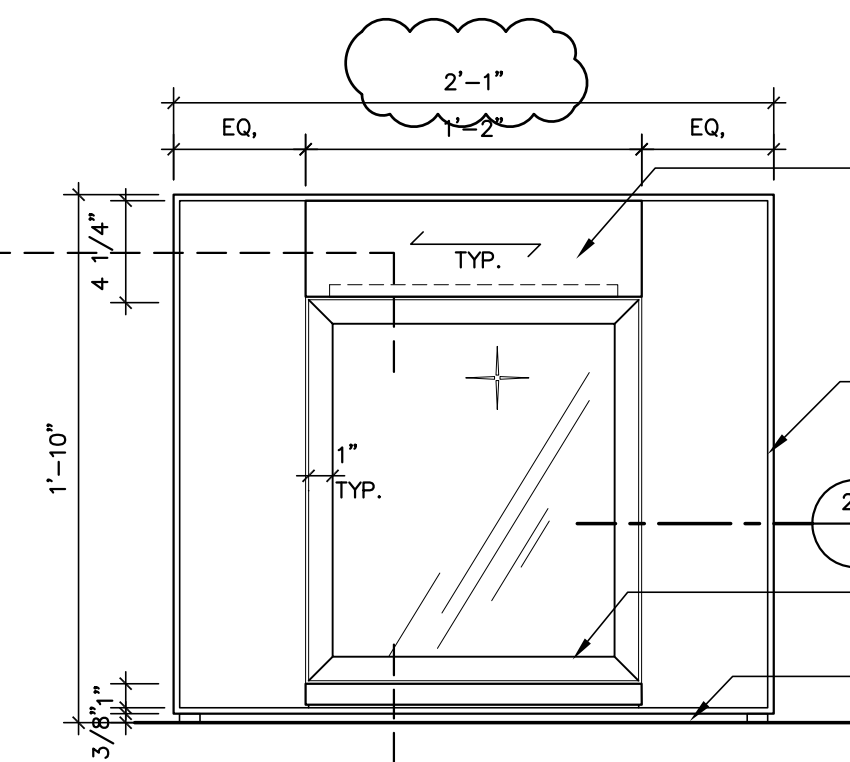
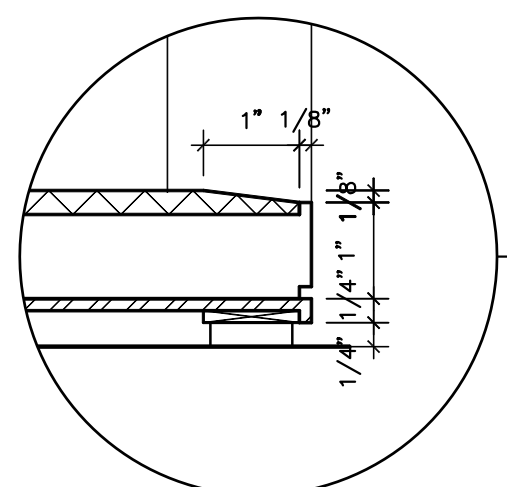
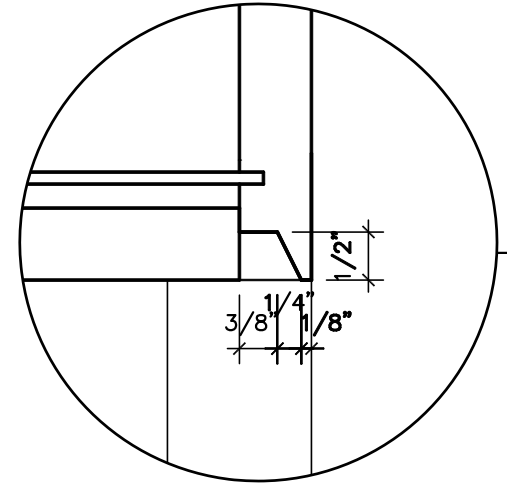
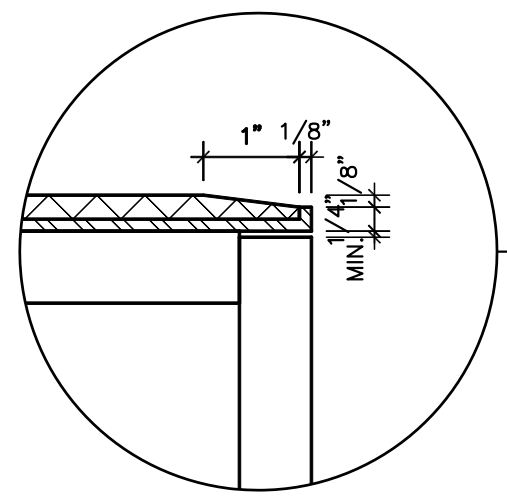

**1B** FRONT ELEVATION  
 SCALE: 1 1/2" = 1'-0"

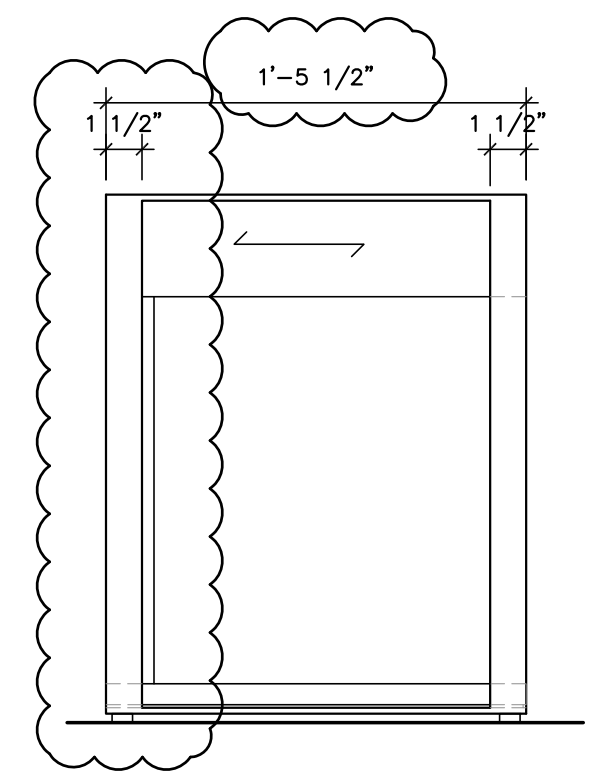

**1C** SIDE ELEVATION  
 SCALE: 1 1/2" = 1'-0"

ISSUE	ISSUE DATE
1	100% CD NOV 4, 2011
2	BULLETIN 8 REVISION #1 OCT 26, 2012

REVISION PROJECT NO. 07036  
 REVISION DATE PROJECT  
 PARK HYATT - CARNEG  
 57TH STREET BLDG.  
 WEST 57TH STREET  
 NEW YORK, NEW YORK 10019

DRAWING DRAWING NO. 1 OF 2  
 HOT-404-CG  
 FLOORS 4-18  
 HOTEL ROOMS  
 BEDSIDE TABLE

SCALE DATE  
 AS NOTED 11.04.2011  
 DRAWN BY CHECKED BY  
 AG/SP

CONTRACTOR MUST CHECK AND VERIFY ALL JOB DIMENSIONS, DRAWINGS, DETAILS AND SPECIFICATIONS REPORT ANY DISCREPANCIES TO DESIGNERS BEFORE PROCEEDING WITH WORK



GENERAL

NOTES

1. ALL MDF TO BE FINISHED WD2
2. DENOTES WOOD GRAIN DIRECTION.
3. ALL METAL TO BE FINISHED ML1
4. ALL MIRROR TO BE FINISHED MR13 UNLESS NOTED OTHERWISE

ISSUE ISSUE DATE

1	100% CD	NOV 4, 2011
2	BULLETIN 8 REVISION #1	OCT 26, 2012

REVISION REVISION DATE

PROJECT PROJECT NO. **07036**  
**PARK HYATT – CARNEGIE**  
**57TH STREET BLDG.**  
**WEST 57TH STREET**  
**NEW YORK, NEW YORK 10019**

DRAWING DRAWING NO.  
HOT-404-CG  
2 OF 2

FLOORS 4-18  
HOTEL ROOMS  
BEDSIDE TABLE

SCALE DATE  
AS NOTED 11.04.2011  
DRAWN BY CHECKED BY  
AG/SP

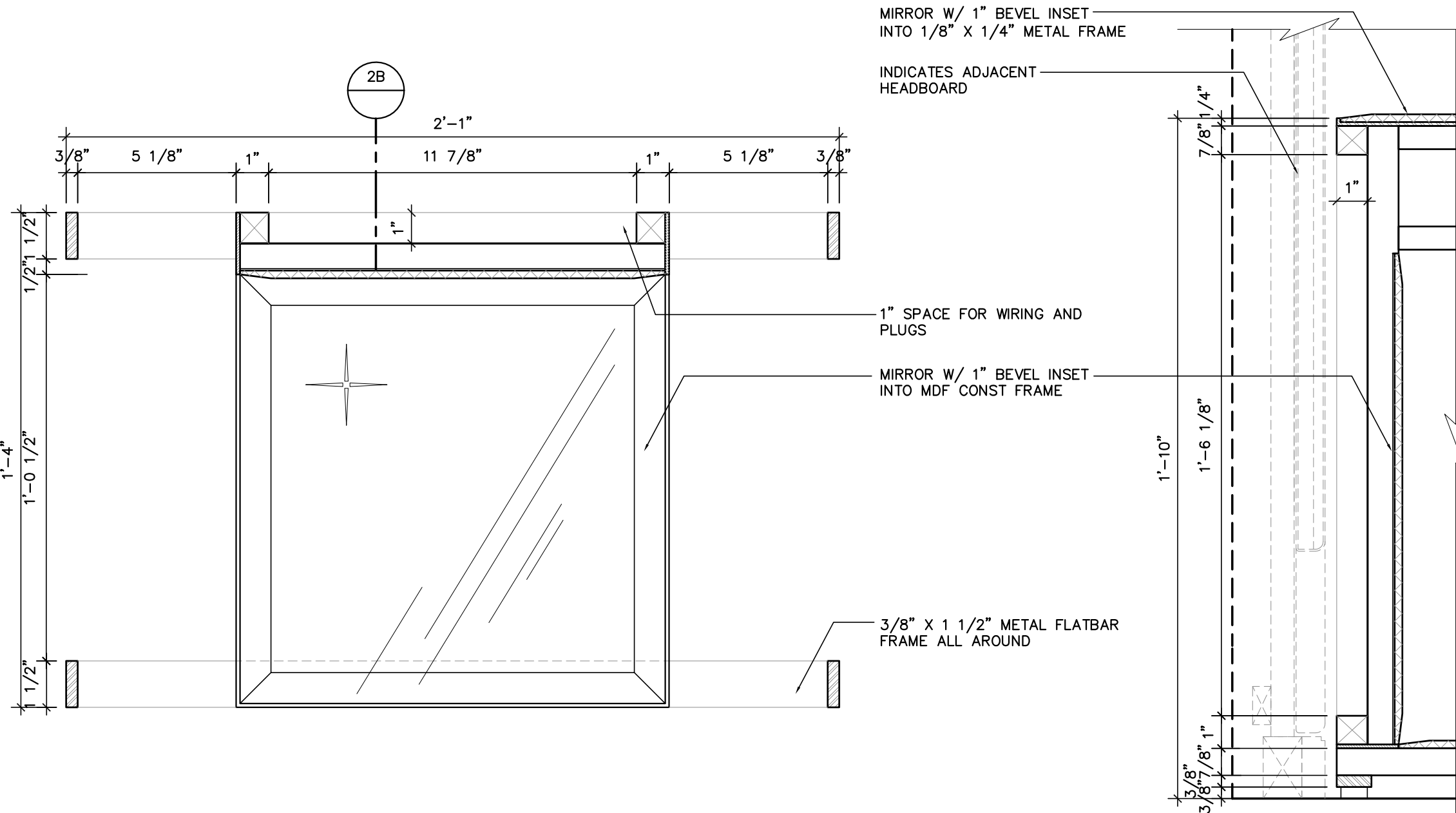

**2A** PLAN  
SCALE: 3/4"=1'-0"

**2B** PLAN  
SECTION  
SCALE: 3/4"=1'-0"



Project Name: **PARK HYATT / CARNEGIE- NYC**  
 Project #: **07036**  
 Issue Date: **08/31/2009**  
 Revision(s): **09/30/2011** Δ 3  
New Notes and Drawing

Item Number: **HOT-501B-LT**  
 Item Description: **Bedside Lamp- Custom**  
 Area Name: **Hotel Room**

Item Quantity:

Manufacturer: By Custom Lighting Manufacturer	Source: By Custom Lighting Manufacturer
Address:	Address:
Phone:	Phone:
Fax:	Fax:
Contact:	Contact:
E-mail:	E-mail:
Web:	Web:

Description: Custom Bedside Lamp  
 Refer to drawing HOT-501-LT for details.

Cord Color: Black

Shade/Diffuser Material: White Linen Shade

Dimmer: Dimmer to be on base

Finish References: ML-01 Plated Finish / Brass Substrate - BASE

Notes: HOT-501A-LT and HOT-501B-LT are the same fixture. The shade and stem are to remain in the same orientation, but the base is to be mirrored for right and left handed conditions.  
 HOT-501A-LT to have left handed orientation.  
 HOT-501B-LT to have right handed orientation.

Required Item(s) for Designer Approval Prior to Fabrication: Prepared By: MR

<input type="checkbox"/> Seaming Diagram	<input type="checkbox"/> Strike-Off	<input checked="" type="checkbox"/> Finish Sample	<input type="checkbox"/> Cutting	<input checked="" type="checkbox"/> Shop Dwgs	<input checked="" type="checkbox"/> Prototype	<input type="checkbox"/> Flame Certificate
--	-------------------------------------	---	----------------------------------	---	---	--

1. MANUFACTURE TO SUBMIT CHAMPAGNE METAL FINISH FOR APPROVAL

2. SUBMIT FABRIC FOR APPROVAL

NOTE: HOT-501A-LEFT ORIENTATION  
 HOT-501B-RIGHT ORIENTATION

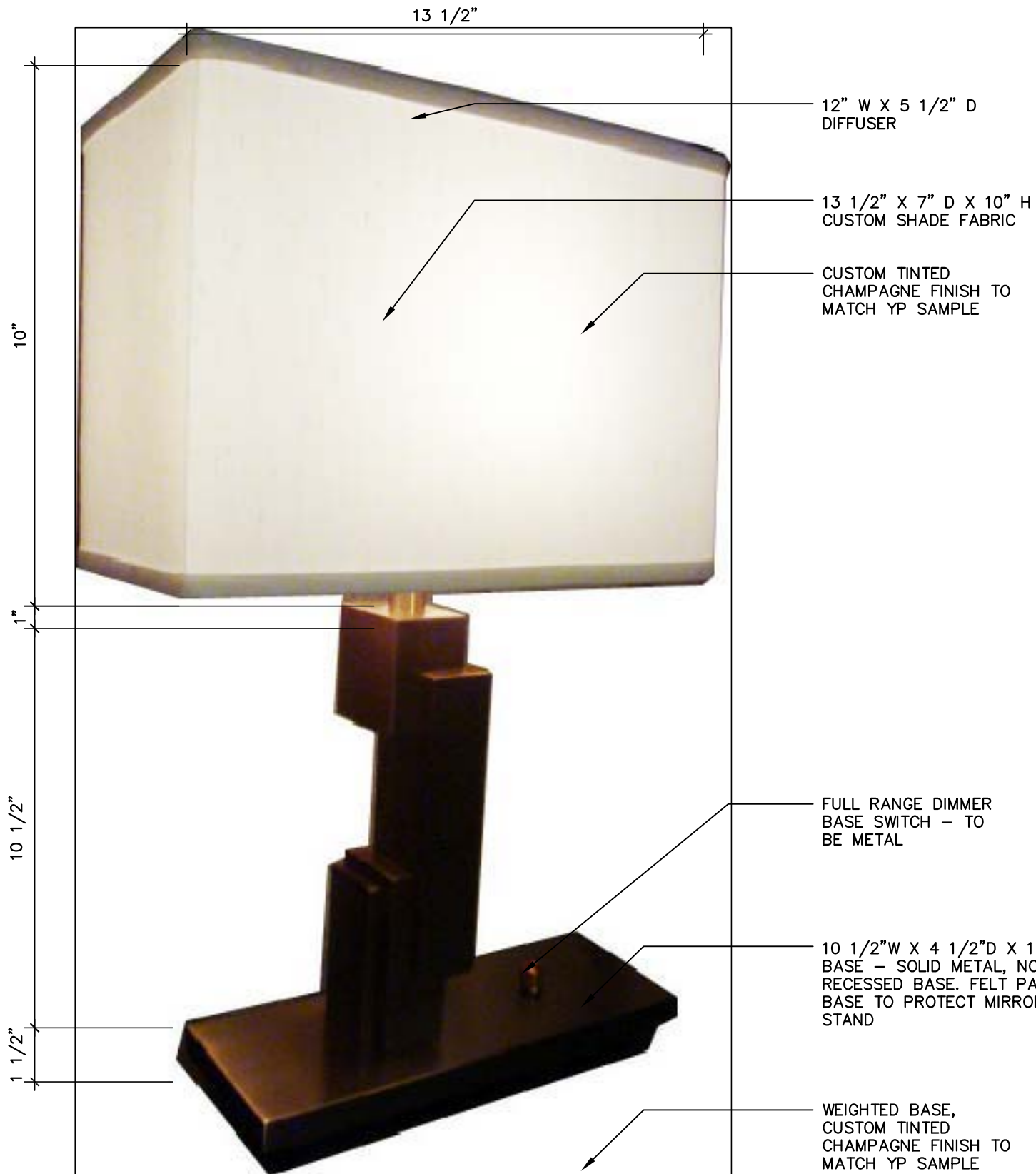

2 IMAGE  
N.T.S.



3 IMAGE  
N.T.S.

1 IMAGE  
N.T.S.

ISSUE ISSUE DATE

REVISION REVISION DATE  
 PROJECT PROJECT NO. 07036  
 PARK HYATT - CARNEGIE  
 57TH STREET BLDG.  
 WEST 57TH STREET  
 NEW YORK, NEW YORK 10019

DRAWING DRAWING NO.  
 HOT-501-LT  
 1 OF 1

GUEST ROOMS  
 NIGHT STAND  
 TABLE LAMP

SCALE DATE  
 AS NOTED SEPT. 2011  
 DRAWN BY CHECKED BY  
 RA

Project Name: **PARK HYATT / CARNEGIE- NYC**  
 Project #: **07036**  
 Issue Date: **08/31/2009**  
 Revision(s): **09/30/2011** Δ 3  
New Notes and Drawing

Item Number: **HOT-417A-CG**  
 Item Description: **TV Credenza- Custom- 5'-6"**  
 Area Name: **Hotel Room**

Item Quantity:

Manufacturer: By Millwork Contractor  
 Address:

Source: By Millwork Contractor  
 Address:

Phone:

Phone:

Fax:

Fax:

Contact:

Contact:

E-mail:

E-mail:

Web:

Web:

Description: Custom TV Credenza - 5'-6"  
 Refer to drawing HOT-417A&B&C-CG for design details

Finish References: ML-01 Plated Finish / Brass Substrate -  
 WD-28 Polyester Lacquer / 100% High Gloss /  
 Carbon Copy / BM2117-10 / 1 -  
 MR--17 Bronze Satin Mirror w/ Enduroshield  
 protective coating -

Notes: Location= Guestrooms

Required Item(s) for Designer Approval Prior to Fabrication:

Prepared By: CG

<input type="checkbox"/> Seaming Diagram	<input type="checkbox"/> Strike-Off	<input checked="" type="checkbox"/> Finish Sample	<input type="checkbox"/> Cutting	<input checked="" type="checkbox"/> Shop Dwgs	<input type="checkbox"/> Prototype	<input type="checkbox"/> Flame Certificate
--	-------------------------------------	---	----------------------------------	---	------------------------------------	--

Instructions:

- 1 Any materials used must be suitable for use in location specified and varying climatic situations.
- 2 All work is to be corner blocked, well fitted, double doweled, glued, and screwed into place. Joint glue must be of the best quality and any excess glue will be thoroughly cleaned.
- 3 All items are to be mill fabricated according to the size and design indicated on the approved shop drawings.
- 4 Legs and bases must be made of wood solids.
- 5 All drawer fronts will be as specified and should be made of lumber or veneer plywood.
- 6 Drawer sides, backs and sub fronts will be made of 13 mm (1/2") solid lumber or veneered plywood.

Project Name: **PARK HYATT / CARNEGIE- NYC**  
 Project #: **07036**  
 Issue Date: **08/31/2009**  
 Revision(s): **09/30/2011** Δ 3

Item Number: **HOT-417A-CG**  
 Item Description: **TV Credenza- Custom- 5'-6"**  
 Area Name: **Hotel Room**

Item Quantity:

Manufacturer: By Millwork Contractor  
 Address:

Source: By Millwork Contractor  
 Address:

Phone:

Phone:

Fax:

Fax:

Contact:

Contact:

E-mail:

E-mail:

Web:

Web:

Instructions:

- 7 Drawer bottoms will be made of solid lumber or veneered plywood. Drawer bottoms may not be made of Masonite or particleboard.
- 8 Drawer sides will be dovetailed or butterfly jointed and glued under pressure. The dovetails will be milled true and even.
- 9 Drawer and door interiors must be veneered and finished to match the exterior of the unit.
- 10 Drawer and door interiors will be sanded smooth, lacquered and waxed.
- 11 All drawers will have a stop mechanism that is removable when required for repairs or access.
- 12 All cabinet doors will be as specified and should be made of 19 mm (3/4") lumber or veneered plywood or as required.
- 13 Cabinet door interiors must be veneered and finished to match the exterior of the unit.
- 14 All adjustable shelving will be made of solid wood or veneered plywood unless otherwise specified.
- 15 For all shelves, the top, bottom, and side edges must match the exterior of the unit.
- 16 All casegood hardware and accessories will be furnished and installed by the vendor and must be indicated on the shop drawings.
- 17 All drawers and pull out shelves will have concealed, undermounted hardware. Full extension, metal drawer glides or shelf slides with ball bearing nylon rollers are required. These should be self-closing and have stops.
- 18 All casegood and softgood legs and bases will have self-leveling adjustable nylon contract quality carpet glides, appropriate to the weight of the piece and the floor finish on which the casegood will be placed.
- 19 All glides and levelers will be non-rusting.
- 20 The casegood vendor will supply templates for all glass tops when supplied by others.

GENERAL NOTES

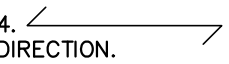
1. ALL METAL TO BE **ML1**
2. ALL WOOD TO BE **WD28**
3. ALL MIRROR TO BE **MR17**
4.  DENOTES WOOD GRAIN DIRECTION.
5. ALL MDF TO BE 3/4" THICK UNLESS NOTED OTHERWISE
6. CONTRACTOR TO PROVIDE LEVELERS

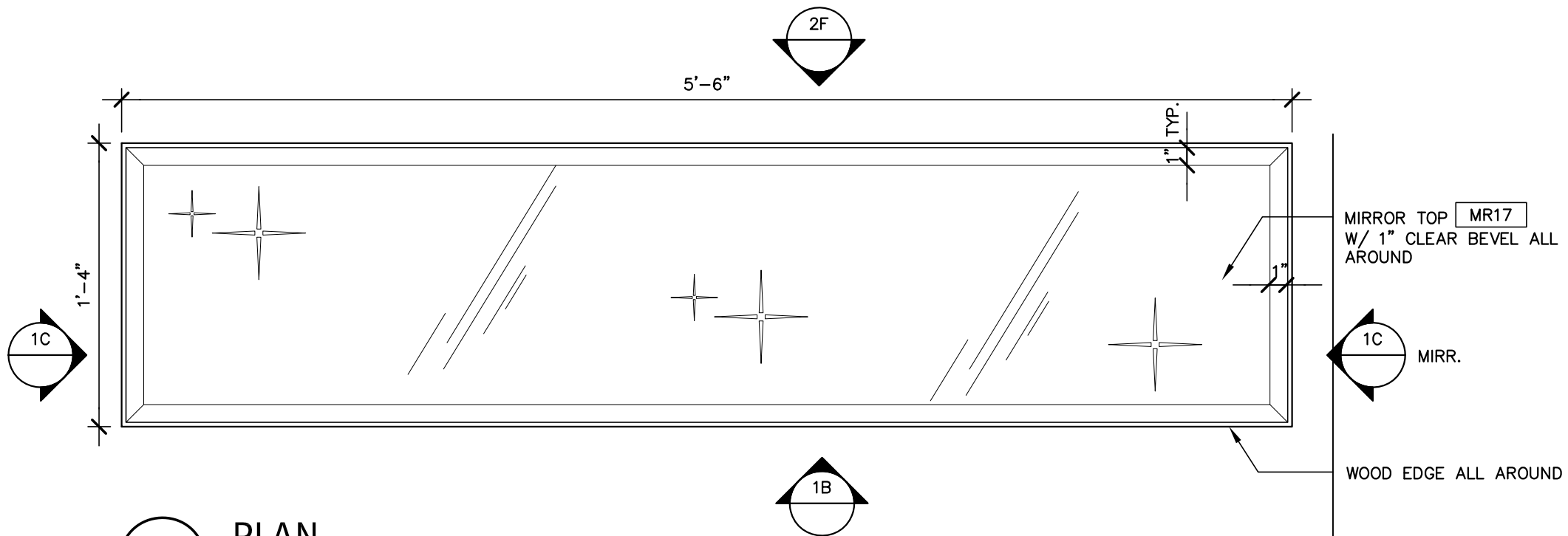

**1A PLAN**  
SCALE: 1 1/2"=1'-0"

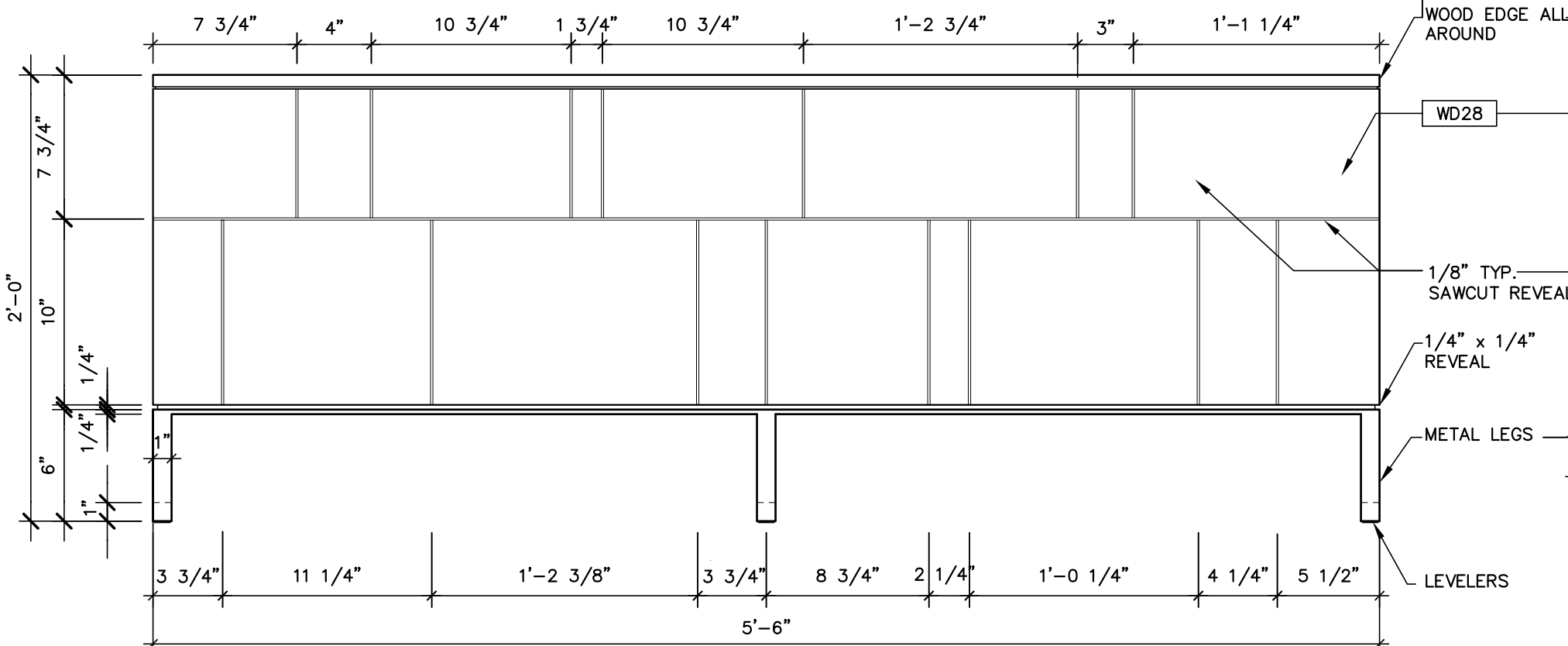

**1B FRONT ELEVATION**  
SCALE: 1 1/2"=1'-0"

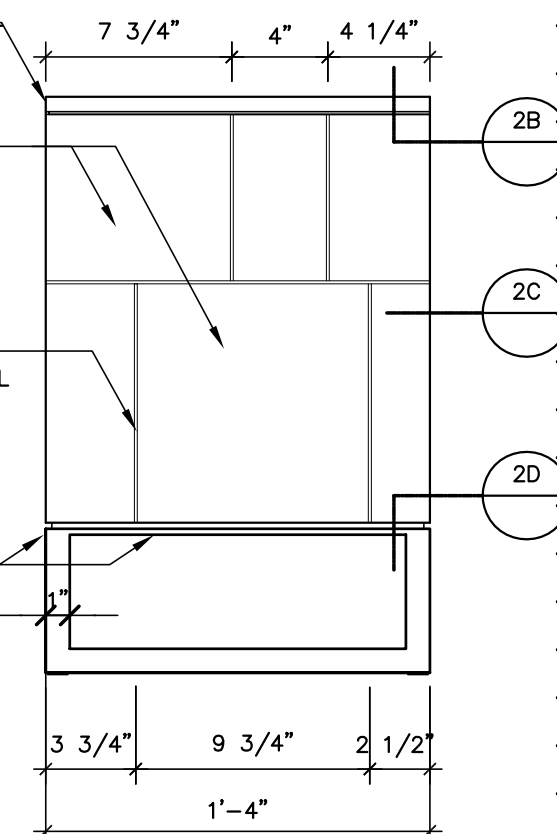

**1C SIDE ELEVATION**  
SCALE: 1 1/2"=1'-0"

ISSUE	ISSUE DATE

REVISION	REVISION DATE

PROJECT PROJECT NO. 07036  
**PARK HYATT - CARNEGIE**  
**57TH STREET BLDG.**  
WEST 57TH STREET  
NEW YORK, NEW YORK 10019

DRAWING	DRAWING NO.
	HOT-417-A-CG

**FLOORS 4-18**  
**DOUBLE ROOM**  
**CRENZENZA**  
1 OF 2

SCALE	DATE
AS NOTED	09.30.2011
DRAWN BY	CHECKED BY
AG	

CONTRACTOR MUST CHECK AND VERIFY ALL JOB DIMENSIONS, DRAWINGS, DETAILS AND SPECIFICATIONS REPORT ANY DISCREPANCIES TO DESIGNERS BEFORE PROCEEDING WITH WORK

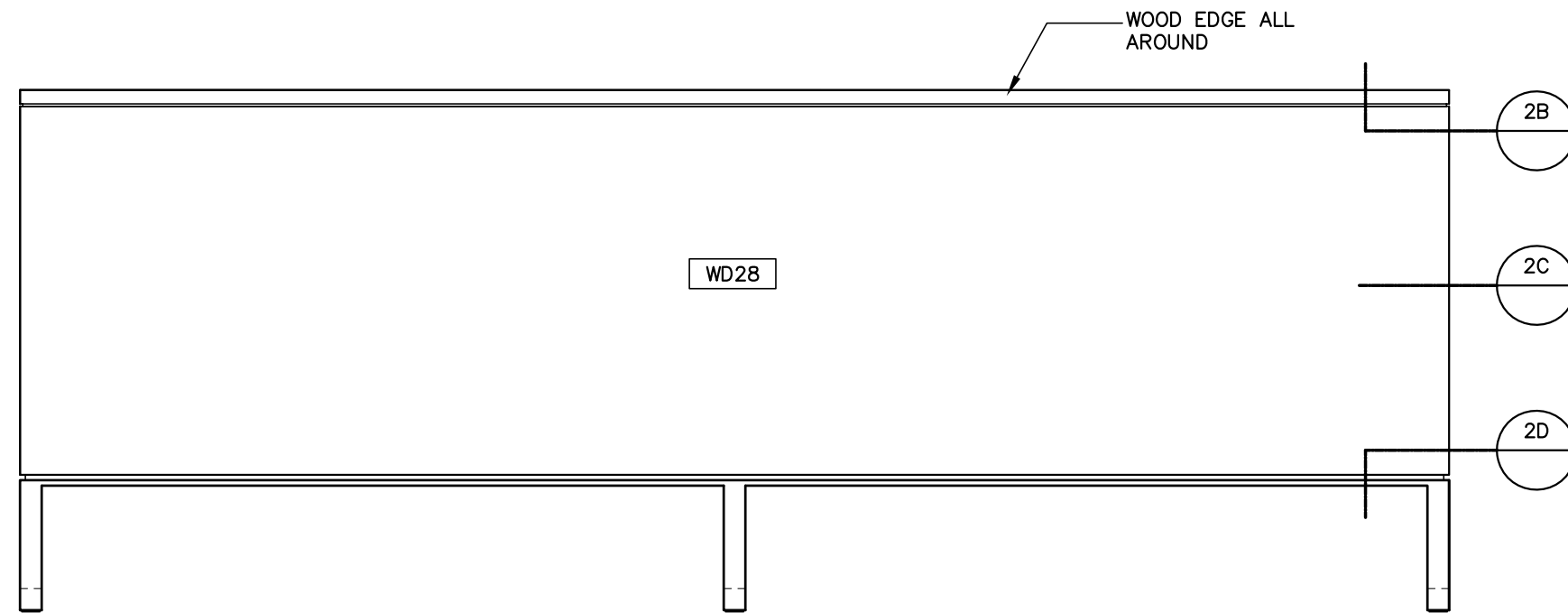

**2A** BACK ELEVATION  
 SCALE: 1 1/2"=1'-0"

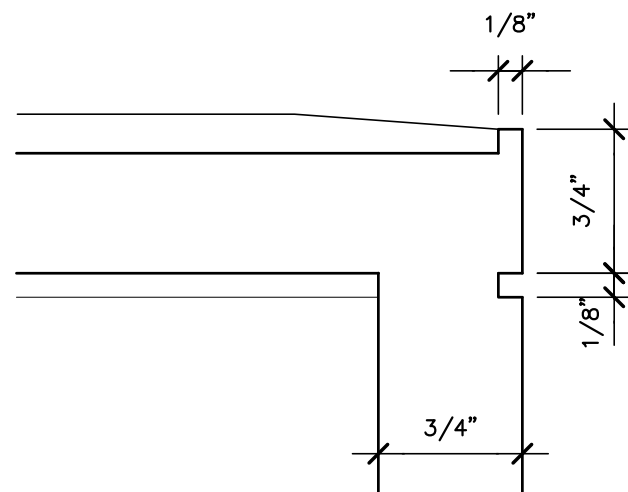

**2B** SECTION DETAIL  
 SCALE: FULL SCALE

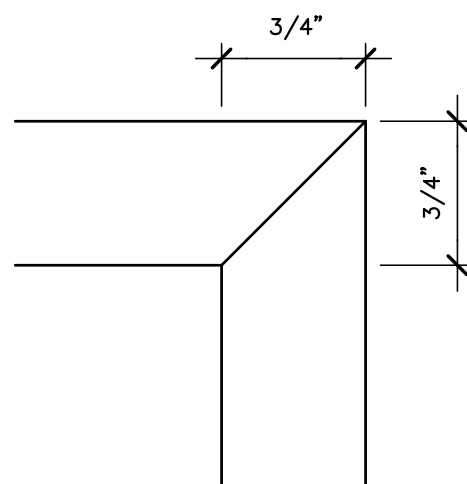

**2C** PLAN DETAIL  
 SCALE: FULL SCALE

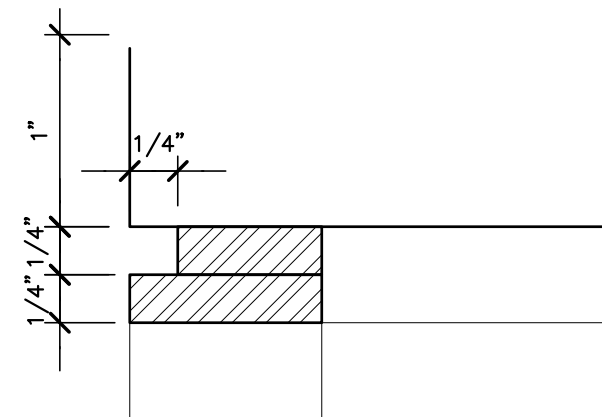

**2D** LEG SECTION DETAIL  
 SCALE: FULL SCALE

GENERAL NOTES

1. ALL METAL TO BE **ML1**
2. ALL WOOD TO BE **WD28**
3. ALL MIRROR TO BE **MR17**
4. DENOTES WOOD GRAIN DIRECTION.
5. ALL MDF TO BE 3/4" THICK UNLESS NOTED OTHERWISE
6. CONTRACTOR TO PROVIDE LEVELERS

ISSUE	ISSUE DATE

REVISION	REVISION DATE

PROJECT PROJECT NO. 07036  
**PARK HYATT - CARNEGIE**  
**57TH STREET BLDG.**  
 WEST 57TH STREET  
 NEW YORK, NEW YORK 10019

DRAWING	DRAWING NO.
	<b>HOT-417-A-CG</b>

FLOORS 4-18  
**DOUBLE ROOM**  
**CREDENZA**

2 OF 2

SCALE	DATE
AS NOTED	07.22.2011
DRAWN BY	CHECKED BY
AG	